

## **University of Florida Telecommunication Standards**

May 2005

This document is designed to assist certified designers such as Professional Engineers and Registered Communications Distribution Designers (RCDD<sup>®</sup>) in the preparation of telecommunications documents in the appropriate Construction Specifications Institute (CSI) format that will accompany a full set of Telecommunications drawings for new construction projects, major renovation projects, and minor renovation projects on the University of Florida Campus. This document is also intended as a standard by which all low voltage telecommunications infrastructure shall be installed University wide.

Suggested changes to this document or variances from this standard must be coordinated for approval through the Network Infrastructure Coordinator with Network Services in the Office of Information Technology at 352-392-2061.

<b>Table of Contents:</b>	<b>Page</b>
1. INTRODUCTION.....	3
2. ENTRANCE FACILITY.....	6
3. MAIN TELECOMMUNICATIONS ROOM (MTR).....	9
4. TELECOMMUNICATIONS ROOMS.....	12
5. BACKBONE PATHWAYS.....	14
6. HORIZONTAL PATHWAYS.....	16
7. WORK AREAS.....	18
8. BACKBONE CABLE.....	19
9. HORIZONTAL CABLE.....	21
10. GROUNDING AND BONDING.....	24
11. DELIVERABLES.....	25
12. VIDEO SPECIFICATIONS GUIDELINES - CAMPUS CABLE TV.....	27
13. OUTSIDE PLANT.....	28
14. AERIAL PATHWAYS.....	30
15. UNDERGROUND PATHWAYS.....	31
16. VAULTS AND PEDESTALS.....	37
17. APPENDIX #1 - UF LABELING AND NAMING CONVENTIONS IN ACCORDANCE WITH ANSI/TIA/EIA-606-A.....	42
18. APPENDIX #2 -GROUNDING AND BONDING.....	66
19. APPENDIX #3-TELECOMMUNICATION ROOM DESIGN EXAMPLE.	68
20. APPENDIX #4 - STANDARDS VARIANCE FORM.....	72

## **1. Introduction**

1.1.1. Communication technologies are a critical element in the design of all new and renovation building projects. Whether it be voice, data and video transmission, security and fire alarm systems, building automation systems, audio/visual systems, or other communication technologies, it is important that a team of experienced professionals be involved in the design of these complex systems.

1.1.2. A Structured Cabling Plant is a key concept in enabling Information Technology for UF's community. In order to maximize network functionality, and to minimize labor and materials costs, a common set of network codes and standards shall be complied with. To accomplish this, UF has adopted a policy in which these codes and standards are managed and administered centrally. UF's OIT is charged with this responsibility.

1.2. **General:** Designers shall verify that all applicable portions of these standards are incorporated into the project's design, drawings, specifications and final construction. Requests for variances from these standards shall be submitted in writing to UF's Infrastructure Group within the Office of Information Technology (OIT), using UF's Standards Variance Request Form found in Appendix 4 for review and written approval or rejection as indicated on the form.

1.3. **Telecommunications Projects Eligibility Requirements:** All projects designed by a consulting architect/engineer, shall have the telecommunications infrastructure designed by the consultant team (Designer) and installed by the Contractor. This infrastructure shall include all pathways, cabling, terminations, testing and closet construction related to the telecommunications systems. The Designer shall provide these services in accordance with these standards, and as directed by University of Florida's Office of Information Technologies (OIT).

1.4. **University of Florida's Final Provisioning Work for all Projects:** For all construction projects for the University of Florida, Construction budgets are required to fund all internal and external telecommunications assets. This includes all wiring, connectivity products, electronics, handsets, etc. Further, the construction budget is required to pay for any additions to outside plant infrastructure that is needed to support the operation of the building. Designers and Contractors shall be required to develop construction schedules that allow adequate time for OIT to complete this final provisioning work, prior to Substantial Completion and the Owner's occupancy of each part of a project.

1.4.1. Contractors shall be required to cooperate with OIT personnel and allow them equal access to the jobsite to inspect and complete any work necessary in the completion of the project, concurrent with other work underway by the Contractor. OIT may be contacted by calling 352-392-2061

**1.5. Codes and Standards:** UF's communications systems shall follow the codes and standards set forth in the following: NEC, NESC, NFPA, ANSI/TIA/EIA Telecommunications Building Wiring Standards, FCC, IEEE and BICSI'S Telecommunications Distribution Methods Manual. These codes and standards are to be used as references when designing telecommunications systems.

1.5.1. The University of Florida promotes the use of widely accepted industry standards in deploying the University telecommunications infrastructure. Employees of the university, consultants and contractors working on behalf of the university should have a working knowledge of these standards prior to performing work for the university and should follow the university preferred standards and practices while deploying telecommunications infrastructure. University employees, consultants and contractors should contact OIT for clarification and interpretation of these standards. The following standards are practiced at the University of Florida:

- ANSI/TIA/EIA-568-B.1.2.3 Commercial Building Telecommunications Cabling Standard (May 2001)
- ANSI/TIA/EIA-569-A Commercial Building Standard for Telecommunications Pathways and Spaces (February 1998)
- ANSI/TIA/EIA-606-A Administration Standard for the Telecommunications Infrastructure (May 2002). See Appendix 1 for the current UF Labeling standard based on ANSI/TIA/EIA-606-A
- ANSI J-STD-607-A Commercial Building Grounding and Bonding Requirements for Telecommunications (August 1994)
- ANSI/TIA/EIA-758 Customer-Owned Outside Plant Telecommunications Cabling Standard (February 1999)
- ANSI/TIA-862 Building Automation Systems Cabling Standard for Commercial Buildings
- NECA 1-2000, Standard Practices for Good Workmanship in Electrical Construction

1.5.2. These standards can be obtained through BICSI at [www.bicsi.com](http://www.bicsi.com) as well as [www.tiaonline.org](http://www.tiaonline.org). This manual is based on the version of the standards indicated. In practice, the most recent version shall be used.

1.5.3. These standards are NOT to be used as the final specification or bid document for any specific new construction. This document is to be used as a starting point in a process of collaboration between the architect/designer, the occupant, and OIT.

1.5.4. Detailed specific requirements for the particular project at hand will depend on the unique purpose of the space(s) of that project and shall be supplied during the design phase of the space in that collaboration.

1.5.5. The design team shall include the resources needed to fully develop a complete scope of work for all telecommunications, I/T, and audio/visual systems and components (including BICSI or RCDD qualified staff).

- Bicsi: Formally known as BICSI, the Building Industry Consulting Service International, Inc.
- (RCDD): Registered Communications Distribution Designer

1.5.6. Telecommunications plant work (exterior of facility) may be purchased by the project through OIT-CNS (Office of Information Technology – Computing and Networking Services). The architect/engineer shall coordinate with OIT-CNS to eliminate conflicts with other utilities, landscaping, etc., shall include all such work "by others" in the construction documents, and shall ensure that no gaps exist between the contractors' scope of work and the scope(s) of work "by others." Building interior telecommunication installation must be preformed by a contactor who is qualified by OIT-CNS. OIT-CNS maintains a list of pre-qualified Low-Voltage Contractors; this list and the procedure for qualifying as an approved contractor can be found at:

<http://net-services.ufl.edu/infrastructure/>

1.5.7. Interior voice & data work shall be designed, specified, packaged, and competitively procured, as are other trades. OIT shall have approval authority in the bidder pre-qualification process. All such work shall be included in the construction documents and coordinated by the architect/engineer.

1.5.8. Bid Documents: It is expected that the result of this collaboration shall be the creation by the design team of a bid-quality document that contains commonly accepted and standard language of the industry. These documents are to include a set of appropriate division specifications (e.g. Division 17 for older CSI formats or Divisions 25, 27, and 28 for the new CSI Master Format) as well as Telecommunications Drawings or Sheets (a.k.a. T-Drawings or T-Sheets).

## 2. Entrance Facility

2.1.1. The Entrance Facility (EF) is the main telecommunications building service entrance. It is the area where the demarcation between the inter-building and intra-building cabling systems is effected. This securable room is to be dedicated to this purpose with no other building services sharing the space. This room can be collocated with the Main Telecommunications Room. In the case of collocation of the Entrance Facility and the Main Telecommunications Room, the Entrance Facility square footage must be added to that of the Main Telecommunications Room to accommodate for the entrance conduit, cable, and breakout.

2.2. **Size:** A minimum of 35 square feet must be provided to house the Entrance Facility of a new building. This space may be expanded for larger buildings.

2.2.1. Minimum ceiling height is 9' 6", with the bottom of the exposed structure considered the ceiling. The wall shall extend to the bottom of the exposed structure. There shall be no suspended ceiling.

2.2.2. All rooms shall be square or rectangular with walls at right angles to each other. No triangular rooms or walls with curves shall be allowed. No columns shall be allowed inside the room.

2.3. **Location:** The service entrance room location shall be as close as practicable to of the point where the electrical facilities enter the building. This room shall be completed early in the construction phase to allow for the installation of the copper, fiber and broadband feeder cables to the room. The room shall be dedicated to Telecommunications Services.

2.4. **Casework in an Entrance Facility:** When installing a floor-mounted rack or cabinet, without panels, fasten the rack or cabinet to the floor and bond the rack or cabinet to the ground bus. Location of the rack or cabinet will be identified during the design phase of the project and reviewed by OIT and the user group. All racks shall be installed with an insulating pad between the rack and the floor. Two post racks shall be secured to the wall behind them with a ladder rack.

2.5. **Disconnect Modules:** The University's Outside Plant Manager shall coordinate with the public utility on the installation of the building entrance terminal protectors when the feeder cables are installed.

2.6. **Door:** Rooms shall have a fully opening, lockable door opening into an indoor publicly accessible area. The door shall be at least 36" wide and 80" in height. The door shall be keyed to match UF's EDC key.

2.7. **Electrical:** Along all walls there shall be one 120 Vac/20A electrical duplex outlet NEMA 520R every 6 ft at 6" AFF. This should be below the plywood backboard.

2.7.1. Along the rear wall of the Entrance Facility or on the rack where the equipment that uses the services will be located, shall be one 208Vac/30A duplex outlet NEMA L630R and one 120 Vac/30A duplex outlet NEMA L530R. Each of these outlets shall be on a dedicated circuit.

2.7.2. Every electrical outlet shall be labeled with printed labels to indicate the serving power panel and breaker.

2.8. **Grounding:** Provide a building ground cable, with bus bar, to the room. Locate the bus bar at the lower left corner of the plywood backboard. Refer to Grounding section of these standards. (See Grounding and Bonding – Appendix 2)

2.9. **Identification:** The Entrance Facility shall be identified and labeled per UF Facilities Planning & Construction standard procedures. Room numbers only shall be used where required by applicable security regulations.

2.10. **Interior Finishes:** To minimize dust, floors shall be of vinyl composition tile. All exposed concrete, brick and gypsum board walls shall be painted or sealed.

2.11. **HVAC:** Per TIA/EIA Standard

2.12. **Lighting:** Per TIA/EIA Standard

2.13. **Pathways entering the Entrance Room:** The number and type of telecommunications circuits that will be brought into the building shall determine the number and size of inter-building conduits entering this room. The minimum number and size of conduits to a building is four (4) 4" conduits, with one of the conduits having four (4) 1" innerducts. All service entrance conduits shall terminate in the service entrance room.

2.13.1. If the Service Entrance room is not serving as the Main Telecommunications Room for the building then an equal number of 4" conduits must be installed to connect these rooms. One (1) of these 4" conduits shall contain four (4) 1" innerducts. All service entrance conduits shall terminate in the service entrance room.

2.14. **Pathways in the Entrance Facility:** A cable tray shall be installed that will encircle the room at 8.5' AFF. Additionally, trays shall be installed to service equipment rows, cross-connect areas, and conduits entering the room.

2.14.1. Bond each section of the cable tray to the ground bus per NEC. Location of the cable tray shall be identified by OIT during the design phase of the project.

2.15. **Plumbing:** Entrance Facility shall not have any water pipes within the room's interior space, routing horizontally on the floor directly above the room, or within the floor slab below the room.

2.16. **Plywood Backboard Panels:** Each wall shall have 3/4" X 4' X 8' sheets of A-C Grade plywood installed on them for anchoring termination strips and other devices. The plywood backboard panels shall be painted on front, back, and sides with two coats of low-gloss latex paint with fire retardant additive. Plywood shall be painted with neutral color paint. The finished plywood shall be labeled indicating the fire resistive additive. 3/4" X 4' X 8' Fire retardant A-C Grade plywood may be used instead of fire-retardant coated plywood.

2.16.1. The plywood shall reach from corner to corner. Install the plywood vertically at 12" AFF and anchor securely to wall substrate with a minimum of five (5) equally spaced fasteners along each vertical edge and down the centerline of each sheet of plywood. Fasteners must be flush with surface of backboard. Fasteners shall be of the appropriate type for each substrate. Provide blocking or additional studs in framed walls to receive plywood backup panel fasteners.

2.17. **Card Key Access and Security:** UF Security Policy calls for the protection of all IT infrastructure, equipment, and hardware located within a building. In keeping with this policy, all entrance rooms shall be designed with Card Key electronics access systems for secure entry and monitoring. Systems employed must match those currently being deployed throughout campus. UF's IT Security Policy can be found at <http://net-service.ufl.edu/policies/security>.



### **3. Main Telecommunications Room (MTR)**

3.1.1. This space provides for the demarcation between inter-building and intra-building telecommunications service. This area contains the electronic equipment that transitions between the core campus data, voice and video backbones and the building backbone. This securable room is to be dedicated to this purpose with no other building services sharing the space. This space may be co-located with the Entrance Facility, provided the room is sized for both functions. Main Telecommunications Rooms are generally considered to be building serving rooms.

3.1.2. The room shall be dedicated to telecommunication purposes. A Main Telecommunications Room shall meet all the basic requirements as those previously indicated for the Entrance Facility. In addition, Main Telecommunications Rooms will have additional requirements as noted below.

3.2. **Size:** Each Main Telecommunications Room shall have the minimum size restrictions based on the overall square footages of the ***total building area*** being served.

3.2.1. Total Building Size in Gross Sq. Ft.	Minimum ER Size
up to 20,000	10' x 12'
20,001 to 50,000	10' x 14'
50,001 to 75,000	10' x 20'
75,001 to 200,000	10' x 24'
200,001 to 400,000	14' x 24'
400,001 to 600,000	16' x 24'
600,001 to 900,000	18' x 24'

3.2.2. Where a Main Telecommunications Room will also provide service as an Entrance Facility or Telecommunication Room, the minimum size of the room shall be determined by summing the square footage requirements of all services that will be supplied by that room.

3.3. **Location:** The Main Telecommunications Room shall be located to ensure that the room has access to the intra- and inter-building backbone pathway, is accessible for delivery of equipment, away from potential sources of EMI, away from machinery that causes vibration, and away from steam pipes, drains, and clean-outs. If the Main Telecommunications Room is on a different floor than the Entrance Facility, it shall be vertically aligned above the Entrance Facility Room.

3.4. **Casework in the Main Telecommunications Room:** Install 7' racks or cabinets, without panels, to support video, voice and data network termination devices and electronics. All data equipment shall be rack-mounted and the infrastructure design should reflect this. The amount of service required to

support the building might require more than one rack or cabinet to be installed. Fasten the rack(s) or cabinet(s) to the floor and bond the rack or cabinet to the ground bus.

3.4.1. Number and location of the racks or cabinets shall be supplied during the design phase of the project (see Telecommunications Room Examples – Appendix 3). All racks shall be installed with an insulating pad between rack and floor. Two post racks shall be secured to the wall behind them with a ladder rack. A good working environment for a telecommunications room includes four feet of clear space extending out from the front of the equipment mounted on a wall and four feet out from the front and back of equipment mounted in a rack with two feet of clearance on each side.

3.4.2. All racks and cabinets shall be provided with appropriate cable management for horizontal and backbone cabling. (See Telecommunications Room Examples Appendix 3)

3.5. **Disconnect Modules:** As per Entrance Facility.

3.6. **Door:** As per Entrance Facility.

3.7. **Electrical:** For every rack included in the design, there shall be one 120Vac/30A electrical quadplex outlet NEMA L530R at 90" AFF behind the proposed rack location(s) or installed on the rack.

3.7.1. Along all walls there should be one A/C 20-amp electrical duplex outlet every 6 ft at 6" AFF. This should be below the plywood backboard.

3.7.2. Along the rear wall of the Main Telecommunications Room or installed on the rack where the equipment will be located there shall be one 208Vac/30A duplex outlet NEMA L630R.

3.7.3. A dedicated circuit shall serve every outlet that provides electrical service to networking equipment, such as switches or power supplies. This is not necessary for the general service outlets 6" AFF. Every electrical outlet shall be labeled with printed labels to indicate the serving power panel and breaker.

3.7.4. If optional standby power is available consult with OIT Infrastructure to determine if Main Telecommunications Room shall be included in optional standby power design.

3.8. **Grounding:** As per Entrance Facility.

3.9. **HVAC:** Entrance rooms that house electronics shall have HVAC to control temperature and humidity. The specific BTU's of heating and cooling to be provided will be specific to each room. Temperature and humidity shall be

controlled at 64 to 75 degrees (F) and 30% to 55% respectively. Entrance rooms serving only as cable pass-through and cable concentration locations are not required to be air-conditioned.

3.10. **Identification:** As per Entrance Facility.

3.11. **Interior Finishes:** As per Entrance Facility.

3.12. **Lighting:** As per Entrance Facility.

3.13. **Pathways entering the Main Telecommunications Room:** If the Entrance Facility room is not serving as the Main Telecommunications Room for the building then a minimum of three (3) 4" conduits must be installed to connect these rooms. One (1) of these three (3) 4" conduits shall contain four (4) 1" innerducts.

3.13.1. A minimum of three (3) 4" conduits shall be installed between each Telecommunications room and the Main Telecommunications Room.

3.14. **Pathways in the Main Telecommunications Room:** As per Entrance Facility.

3.15. **Plumbing:** As per Entrance Facility.

3.16. **Plywood Backboard Panels:** As per Entrance Facility.

3.17. **Card Key Access and Security:** As per Entrance Facility.

## **4. Telecommunications Rooms**

4.1.1. These rooms provide for demarcation between the per-floor horizontal service distribution cabling and the building video, data, and voice backbone cabling. A Telecommunications Room provides the connection point between the building backbone and horizontal distribution pathways. These securable rooms are to be dedicated to this purpose with no other building services sharing the spaces. A Telecommunications Room may be co-located with the Entrance Room and/or Main Telecommunications Room provided the room is sized for both functions.

4.1.2. The Telecommunications rooms shall be dedicated to exclusive use for telecommunications purposes. At a minimum, one Telecommunications Room shall be required for every 10,000 sq. ft. of work areas served by the Telecommunications Room. A Telecommunications Room shall meet all the basic requirements as those previously indicated for the Entrance Facility. In addition, Telecommunications rooms shall have additional requirements as noted below.

4.2. **Size:** There are two possible configurations for each Telecommunications Room. The first design is a 10' x 12' room with one door onto a major publicly accessible hallway. This design is preferred.

4.2.1. The second design is a 5' x 14' room with two sets of double doors on the 14' wall of a major publicly accessible hallway (the doors must swing into the hallway). The second design uses the hallway as temporary space during times of maintenance and is most practical in low traffic hallways such as office areas.

4.3. **Location:** A Telecommunications Room shall be centrally located in reference to the area it serves. This is to minimize the horizontal cable lengths and duplication of electronic equipment.

4.3.1. At a minimum, a Telecommunications Room shall be provided for each floor of the building. The Telecommunications Rooms should be located above each other on the different floors. If the Telecommunications Rooms shall not be stacked, the Telecommunications Room shall have a means to access the Telecommunications Rooms on the floor above and below via metal conduits or sleeves.

4.3.2. Maximum horizontal cable tray and conduit combined distance between the Telecommunications Room on each floor and a telecommunications work area data outlet is 200', as measured per the cable pathway.

4.4. **Casework:** As per Main Telecommunications Room.

- 4.5. **Disconnect Modules:** As per Entrance Facility.
- 4.6. **Door:** As per Entrance Facility.
- 4.7. **Electrical:** As per Main Telecommunications Room.
- 4.8. **Grounding:** As per Entrance Facility.
- 4.9. **HVAC:** As per Main Telecommunications Room.
- 4.10. **Identification:** As per Entrance Facility.
- 4.11. **Interior Finishes:** As per Entrance Facility.
- 4.12. **Lighting:** As per Entrance Facility.
- 4.13. **Pathways entering the Telecommunication Room:** If the Telecommunications Rooms are stacked one above another, three (3) 4" sleeves shall be installed between each Telecommunications room. Should Telecommunications Rooms not be stacked, a minimum of three (3) 4" conduits shall be installed between each Telecommunications Room and the Main Telecommunications Room. For Telecommunications bonding backbone, a 1" sleeve or conduit is required for proper grounding pathway. All conduits are required to be fire stopped per NEC.
- 4.14. **Pathways in the Telecommunication Room:** As per Main Telecommunications Room.
- 4.15. **Plumbing:** As per Entrance Facility.
- 4.16. **Plywood Backboard Panels:** As per Entrance Facility.

## **5. Backbone Pathways**

5.1.1. Communications conduit requirements depart from that for “normal” electrical power distribution. Communications conduit sizing does not follow NEC in terms of the maximum number of conductors allowed per unit volume. Due to the need for facilitating frequent additions, moves and changes to the telecommunications systems, communications conduits are generously sized.

5.1.2. Conduits serving as a backbone pathway for telecommunications cables are a minimum of 4”. Conduits serving as a pathway for grounding conductors are a minimum of 1”.

5.1.3. Conduits shall be used to feed the Entrance Facility from the Outside Plant (OSP). Conduits or sleeves shall be used to connect the Entrance Facility to the Main Telecommunications Room. Conduits or sleeves shall be used to connect the Main Telecommunications Room and the Telecommunications Rooms.

**5.2. Entrance Facility Conduits:** Reference the Outside Plant section of this standard for complete design guidelines. The following shall only act as a general guide for initial backbone pathway considerations.

5.2.1. A minimum of four (4) 4” conduits shall be used to provide connections from the Outside Plant into the Entrance Facility. One of these conduits shall be supplied with four (4) 1” innerducts.

5.2.2. Conduits entering the building are a minimum of 4" in size with some type of sub-space partitioning.

5.2.3. Conduits shall terminate 1” to 3” inside the Entrance Facility per TIA-569-B section 8.8.2.7 and be reamed and bushed.

5.2.4. All Entrance Facility conduits shall be sealed so as to be water and gas tight after installation.

5.2.5. Conduits shall not contain more than two 90-degree bends and be placed with a minimum of ¼ inch per foot slope, away from the Entrance Facility, to allow proper water drainage from the ducts.

5.2.6. If the Main Telecommunications Room is not also functioning as an Entrance Facility, conduits or sleeves of equal number and size shall be installed from the Entrance Facility into the Main Telecommunications Room.

5.2.7. An additional 1” conduit or sleeve shall also be provided from the Entrance Facility to the Main Telecommunications Room to provide a pathway for the Telecommunications Bonding Backbone cable.

**5.3. Main Telecommunications Room Conduits:** A minimum of three (3) 4" conduits or sleeves shall be installed between the Main Telecommunications Room and each individual Telecommunications Room.

5.3.1. One (1) 1" conduit or sleeve shall be installed between the Main Telecommunications Room and the Telecommunications Room. The Telecommunications Bonding Backbone cable shall use this conduit or sleeve.

**5.4. Telecommunications Room Conduits:** A minimum of three (3) 4" conduits or sleeves shall be installed between the Main Telecommunications Room and each individual Telecommunications Room.

5.4.1. One (1) 1" conduit or sleeve shall be installed between each Telecommunications Room and the one above. The Telecommunications Bonding Backbone cable shall use this conduit or sleeve.

5.4.2. Conduits between building telecom rooms shall be a minimum of 4" in size.

## **6. Horizontal Pathways**

6.1.1. The standards adopted by this University provide that a clear and accessible pathway for horizontal telecommunications cabling be provided. These pathways are located between the Telecommunications Rooms and the rooms containing the telecommunications outlets. The Design Team shall prepare Telecommunications drawings and specifications that ensure a clear and accessible pathway for telecommunications cabling. **Any pathway that is not accessible or does not provide a clear and workable pathway will be rejected.**

6.1.2. There are several methods available for providing a pathway for supporting telecommunications cables. The architectural design of each building is unique and requires an analysis of which method(s) are best suited for that building.

6.1.3. Only conduits run directly from the Telecommunications Room to the Work Area Outlet or Cable Trays with Work Area feeding conduits are accepted for horizontal pathways. "J hooks" or other similar types of cable pathway devices shall not be used in any new construction or major renovation project design. MUTOA's, CP's, and TP's must be approved through OIT before installation.

6.2. **Cable Trays:** At UF, Cable Trays are the preferred pathways for supporting Horizontal telecommunications cables. Cable Trays shall be provided from the Telecommunications Rooms to support the horizontal cabling. A 1" conduit shall be bonded to the cable tray and extend to the work area outlet box.

6.2.1. The minimum cable tray width is 12" and minimum cable tray depth is 4". The actual cable tray size(s) shall be determined during the design phase of the project. The cable tray shall be installed in accordance with the applicable electrical code. The cable tray is to be dedicated for use only by low-voltage cabling systems. Cable tray shall be trapeze supported or wall mounted. If wall mounted, additional threaded rod supports shall be provided from the ceiling to the outer edge of the wall-mounted tray. Center support cable trays shall not be accepted.

6.2.2. Cable Trays shall have devices installed at all inside corners to prevent minimum cable bending radius from being exceeded.

6.2.3. The specification for this cable tray shall be provided along with the design layout for approval.

6.2.4. Cable tray clearances shall follow ANSI/TIA/EIA 569-B Standards.



6.3. **Horizontal Conduit:** Conduit feeding WAO boxes directly from the Telecommunications Room (home-run) shall be limited to 200' in length. Conduits shall not run continuously for more than 100' before installing a pull box.

6.3.1. Conduits shall not contain more than two 90-degree bends without a pull box. Directional changes shall be made outside pull boxes. At no time shall a pull box be accepted in favor of a bend in the conduit.

6.3.2. Label all conduits as per UF Labeling Standard. (See UF Labeling Standard in Appendix 1) Label all pull and junction boxes with the letters IT (See UF Labeling Standard in Appendix 1).

6.3.3. A minimum of one (1) 1" conduit shall connect from the work area outlet box to the nearest cable tray. Conduits connecting a Work Area Outlet and the Cable Tray shall terminate within 4" and above the cable tray. Conduit fills shall not exceed 40 percent of the conduit capacity.

6.3.4. Conduits shall be reamed and bushed.

6.3.5. Each empty/spare conduit shall contain a nylon pull cord with a 200 LB pulling tension.

6.4. **Prohibited Components:** No LB type fittings of any size are to be used for communication conduit. No PVC conduit or PVC sleeves are to be used for communications conduit within the confines of a building.

6.4.1. Conduit Grounding: Horizontal pathway conduits shall be grounded to the cable tray to ensure a proper grounding path. This may be accomplished by bonding the conduit to the cable tray or using a grounding strap.

## **7. Work Areas**

7.1.1. Design of Work Area Outlets (WAO) change more often than any other piece of the design process. Different needs demand different solutions. As such, this section details only the most basic requirements and innovative designs that keep these minimal standards in mind.

7.1.2. A normal Work Area Outlet must be able to support at least three UTP cables to support telecommunications needs.

7.1.3. Telecommunications outlet boxes installed in drywall, plaster, or concrete block wall must be at least 4 X 4 inches and 2.5 in. deep. All work-area outlet boxes should have a single-gang ring

7.1.4. In general all office areas should have at least two Work Area Outlets. These outlet boxes shall be installed on opposing walls.

7.1.5. The design team shall conduct a wireless survey and design the wireless Ethernet Access System. At least two work area outlets shall be provided at each wireless access point location.

7.1.6. See Horizontal Pathway section of this standard for conduit requirements.

7.1.7. Label all work area outlets (WAO) and WAO terminations. (See UF Labeling Standard in Appendix 1)

7.1.8. See Video section of the standard for details on video cabling and pathways requirements.

## **8. Backbone Cable**

8.1.1. The building backbone system connects Telecommunications Rooms to each other, to the Main Telecommunications Room and the Main Telecommunications Room to the Entrance Facility. UF specifies several separate cable systems to provide for the data, video and voice needs of the building occupants. Riser-rated twisted-pair copper multi-pair cables, coax, and both single-mode and multi-mode fiber along with their termination systems are specified.

8.2. **Entrance Facility to Main Telecommunications Room backbone cable:** Where an Entrance Facility is not collocated with the Main Telecommunications Room the backbone cables connecting these two rooms shall be equal in content to the cables provided to the Entrance Facility from the Outside Plant. These cables may differ in composition (i.e., rated for interior use) than the entrance backbone cable, shall have a pair count, strand count and so on sized for the needs of the building.

8.3. **Copper Cable Backbone:** A minimum of one 100-pair category-3 or better riser cable shall be installed from the Main Telecommunications Room to each Telecommunications Room.

8.4. **Copper Cable Testing & Records:** The contractor shall provide the following electrical test records per the Deliverables section of this document for all backbone copper cables:

- Continuity tests on all pairs (test for opens).
- Test for crosses and shorts, on all pairs.
- Test for loss at 100.4 MHz, on all pairs.
- Test for noise metallic and noise to ground, sampling can be used.
- Test for insulation resistance, sampling can be used.

8.5. **Fiber Optic Cable Backbone:** A minimum fiber optic intra-building backbone cable consisting of 12-strand multi-mode and a 12-strand single-mode shall be installed from the Main Telecommunications Room to each individual Telecommunications Room.

8.6. **Installation:** The fiber-optic backbone cables shall be terminated at all locations in a rack-mounted fiber panel. There shall be 10 ft. of slack jacketed cable managed outside of the fiber panel to facilitate future re-terminations. There shall be 3 ft. of slack (with the outer jacket removed) managed inside the fiber panel. Installation of the required cable slack should be coordinated with the OIT-NS Infrastructure.

8.6.1. Terminate all fiber strands using SC Hot Melt connectors or epoxy/polish connectors. Crimp style connectors shall not be accepted.

8.6.2. Single-mode fiber bulkheads shall have yellow colored covers. Multi-mode fiber bulkheads shall have red colored covers. Bulkheads with no fibers connected to them shall have black colored covers.

8.6.3. Fiber Optic Cable Testing: The contractor on all backbone fiber cables shall provide the following documentation and tests records for each fiber-optic cable installed:

- Identifier as specified by UF Labeling standard (See Appendix 1)
- Termination fiber panel identifiers for both sides of the cable.
- Total fiber-strand type and count in the cable
- Distance in meters for actual cable length
- Test for end-to-end dB loss, both directions, at 850 nm and 1300 nm for multimode and 1310 nm and 1550 nm for single mode for each individual fiber strand.

8.6.4. End to end loss measurements shall be made with a power source and light meter. Multi-mode fiber measurements shall be tested in accordance with ANSI/TIA/EIA-526-14-A method B. Single mode fiber measurements shall be tested in accordance with ANSI/TIA/EIA-526-7 method A.1.

- Maximum allowable loss for splices is .3dB
- Maximum allowable loss for connectors is .5dB per pair

8.7. **CATV Backbone**: (See Video Specification Guidelines)

## **9. Horizontal Cable**

9.1.1. To satisfy today's telecommunications requirements, the horizontal cabling shall be planned to reduce on-going maintenance and relocation. It shall also accommodate future needs since horizontal cabling is often much less accessible than the backbone cabling. In keeping with this effort, Category 5E cabling or better shall be installed in all new construction and major renovations University wide. The time, effort, and skills required for changes can be extremely high. In addition, access to the horizontal cabling frequently causes disruption to occupants and their work. These factors make the choice and layout of horizontal cable types very important to the design of the building cabling. Consideration should be given to accommodating a diversity of user applications in order to reduce or eliminate the probability of requiring changes to the horizontal cabling as user needs evolve.

9.2. **Cabling Distance:** The cable run from the Telecommunications Room to the WAO, consisting of at least three cables, shall not exceed 295 feet and contain no splices. These cables are to provide service for both voice and data communications as an integrated telecommunications system.

9.3. **Cable Installation:** Installation and physical protection of Category 5E or Category 6 cable is a critical element for the cable to deliver its rated bandwidth. A "kink", "pinch", a bend radius less than 1.25 inches in diameter, or the manufacturers specified bend radius, or stretching of the cable by exceeding the 25 pound maximum pulling tension during installation will damage the cable to the point that it will not meet rated specifications and shall be replaced.

9.3.1. No open or exposed wiring or conduits shall be permitted below finished ceilings.

9.4. **Cable Termination:** All UTP horizontal cable should be terminated to T568A pinout. Requirements for terminating Category 5E or Category 6 cable requires that no more than the minimum amount of the common sheath be removed than is required for termination and no more than 1/2 inch of untwisting of conductors.

9.4.1. Horizontal cables shall terminate in a rack-mounted patch panel in the Telecommunications Room. Horizontal cables reserved specifically for non IP-based telephone systems shall terminate into a 110-field termination block.

9.4.2. If modular patch panels are used in lieu of 110-termination type patch panels, the patch panel must be fully populated with modular plugs.

9.4.3. When designing the layout of the Telecommunications Rooms rack-mounted patch panels, racks, UPS's, etc., reference the example provided in this standard. (See Telecommunications Room Example in Appendix 3)

9.5. **Cable Slack:** At the Work Area Outlet, there shall be 12" of slack after termination to facilitate future re-terminations.

9.5.1. In the Telecommunications Room, the wire shall reach the punch-down patch panel and have 10' of slack. Coordinate with OIT-NS Infrastructure on the placement of the managed slack.

9.6. **Cable Type:** Data and voice cables are unshielded twisted-pair cable, each consisting of four twisted pairs of solid conductors type, Category 5E or Category 6. CMP cable shall be used in areas where code requires. The user group may also request that CMP cable be used as well.

9.7. **Clearances:** The installation of these data and voice cables shall conform to the following clearances:

- At least 127 millimeters (5 inches) from power lines carrying 2KVA or less
- At least 305 millimeters (12 inches) from power lines carrying from 2 to 5KVA
- At least 915 millimeters (36 inches) from power lines carrying more than 5KVA
- At least 127 millimeters (5 inches) from all fluorescent lights and other sources of electromagnetic interference

9.8. **Conference Rooms:** (See Video Specification Guidelines)

9.9. **Horizontal cable testing and records:** Each cable shall have a permanent link test performed. For Category-5E-rated links a level II tester or better must be used to certify the cable to 100MHz. For Category-6-rated links a level III tester must be used to certify the cable to 250 MHz.

9.10. **Identification:** Each of the three cables shall be labeled on each end with an appropriate cable identifier (i.e., 1A-1A01). (See UF Labeling Standard in Appendix 1)

9.11. **Elevator Communications:** A single horizontal UTP cable shall be installed to support elevator telephone and emergency communications.

9.12. **Energy Management Systems:** Those energy management systems employing the campus data network for communication shall install their physical infrastructure in accordance with these University Telecommunications standards.

9.13. **Other low voltage cabling systems:** Other low voltage cabling systems must adhere to the telecommunications standards as well. These cables may share the use of common cable trays as needed. These types of cables include, but are not limited to, HVAC control cables, fire control cables, and security systems cables.

9.13.1. If other low voltage systems are to use the campus data network for communicating, these systems must also conform to the campus telecommunications standards.

## **10. Grounding and Bonding**

10.1.1. All cabling systems and electronics-distribution equipment shall be grounded for both safety and minimization of electromagnetic interference. Specifications for this are found in this section. Telecommunications grounding systems are composed of Telecommunications Bonding Backbones (TBB) and Telecommunications Grounding Bars (TGB). Bonding requirements for Telecommunications at the University of Florida follow the ANSI J-STD-607-A standard.

10.1.2. The TBB shall be a green insulated grounding wire with a minimum size of 6 AWG.



## **11. Deliverables**

11.1.1. Architects and contractors have come to accept the rigid industry standards that data communications impose. To a large degree, specialized skill sets required for the design and installation of these systems do not tend towards commodity status. However, unlike power cabling systems, the technology of telecommunications cabling continues to advance dramatically. For this reason UF requires a Registered Communications Distribution Designer (RCDD) on the installation team. Additionally the installed systems must be documented in a way that allows for minimal ongoing labor in the maintenance and management of the installed system.

**11.2. Telecommunication Contractor's Obligations:** The contractor shall furnish and install all material required for a complete structured cabling system, including installation of communication cables, installation of communication outlets, and termination of all cables in the Entrance Facility, the Main Telecommunications Room, and Telecommunications Room.

11.2.1. The contractor shall test and certify all cable and provide documented results of the testing. If any cable run tests defective, the contractor shall replace defective cable.

11.2.2. A one-year materials and labor warranty shall be provided on all cable and hardware installed by the telecommunications contractor. This shall be in addition to any and all factory warranties that can be provided.

**11.3. As-Built Drawings and Information:** The Contractor shall prepare and submit record drawings at an appropriate scale on CDROM.

11.3.1. The record drawings shall convey the following information:

- Locations and Identifiers of all work area outlets.
- All horizontal pathway elements including but not limited to cable tray and conduit.
- Location and identifiers of all Entrance Facilities, Main Telecommunications Rooms, Telecommunications Rooms.
- All backbone pathway elements.

11.3.2. Additionally, as a condition of Substantial Completion, the Contractor shall be responsible for providing the following information:

11.3.3. Concerning the horizontal cable installation:

- Complete test results for each horizontal cable. This test information shall be delivered in electronic, Fluke Linkware compatible format.
- A cable record for each horizontal cable including the following information:
  - Cable identifier as per UF labeling standard (see Appendix 1)
  - Termination point on the host end identified as per UF labeling standard (see Appendix 1)
  - Termination point on the user end identified as per UF labeling standard (see Appendix 1)
  - Termination hardware used at the host end (patch panel type)
  - Termination hardware used at the user end (outlet jack type)
  - Cable type and manufacturer's specification sheet for the cable
  - Presence of a CP, TP, or MUTOA

11.3.4. Concerning the backbone and entrance fiber cable installation

- Complete test results for each backbone fiber cable strand. This test information shall be delivered in electronic, Fluke Linkware compatible format.
- An electronic copy of every insert supplied with every fiber panel
- A cable record for each fiber cable including the following information
  - Cable identifier as per UF labeling standard (See Appendix 1)
  - Termination point on the first end identified as per UF labeling standard (see Appendix 1)
  - Termination point on the second end identified as per UF labeling standard (see Appendix 1)
  - Length of the fiber cable
  - Fiber strand count in the individual cable
  - Cable manufacturer's specification sheet for the cable

11.3.5. Concerning the terminals of UF-owned entrance copper cable

- Each terminal identifier
- Quantity and type of protectors
- Quantity and type of termination blocks
- Cable identifier and pairs entering or leaving

11.3.6. Concerning the UTP riser cable

- Cable identifier
- Cable type
- Size
- Pair counts
- Length of the cable

## **12. Video Specifications Guidelines - Campus Cable TV**

12.1.1. There are multiple video content providers and delivery systems on the campus. Each content provider has different requirements for connection to their delivery system. Video delivery system specifications shall be coordinated with the organization that is chosen to deliver video services to the building.

### **13. Outside Plant**

13.1. **Introduction:** OSP backbone cable shall fulfill all requirements of backbone cable specified in the Backbone Cable section of this standard.

13.2. **OSP backbone fiber cable:** OSP backbone fiber cable shall be loose-buffered cable. Indoor-outdoor loose-tube cable construction is acceptable.

13.2.1. Each new structure shall be connected to the nearest core location (contact OIT-Net Services for locations) or Communications Cabinet with a minimum 12sm/12mm fiber cable. This cable shall pass through the Entrance Facility and terminate in the Main Telecommunications Room. If the Entrance Facility and the ER are not collocated, 20 feet of managed slack shall be placed in the Entrance Facility.

13.2.2. Fiber optics is continuously being deployed on the University campus for voice and data communications. Because of fiber optic cable sizes, the sharing of full-sized conduits is facilitated by the installation of inner-ducts.

13.3. **OSP backbone copper cable:** This cable is to be placed by BellSouth and shall be coordinated with OIT Infrastructure.

13.4. **Splicing Materials:** The University of Florida does not allow splicing of the Outside Plant. If an emergency arises and a splice becomes necessary, contact OIT-Telecom.

13.5. **Permit:** A dig permit from the University of Florida Physical Plant Division must be obtained prior to any excavation. Dig permit procedures may be obtained from the PPD Website at [www.ppd.ufl.edu](http://www.ppd.ufl.edu) or go directly to the instructions at <http://www.ppd.ufl.edu/pdf/DigPermitProc.pdf>.

13.5.1. Trenching must be performed by hand wherever obstacles or existing utility lines are known to be in the area. The contractor is totally responsible for ensuring that no utility or service interruptions occur and that existing utilities or obstructions shall not prohibit installation of service to be provided under this contract at proper grade and location. Where clear and unobstructed areas are to be excavated, appropriate machine excavation is allowed but only when machine weights and operation shall not damage sub-surface structural components or piping.

13.6. **Tree Protection:** All outside work shall be in compliance with UF Construction Standards on tree protection.

13.7. **Concrete Cap:** Occasionally, it shall be necessary to provide extra mechanical protection to mainline or subsidiary conduit in certain areas of campus (normally any conduit placement in the main part\* of campus would be provided with extra mechanical protection). The contractor shall provide a

concrete cap with a minimum thickness of 2" consisting of non-reinforced 2500-psi concrete. There must be a minimum of 6" compacted fill between the top of the conduit and the bottom of the concrete cap. Backfill specifications must be followed. Even with the concrete-cap protection, the metallic warning tape must be placed above the cap. Depending on the depth of the cap, the warning tape should be placed at least 6" above the cap

13.7.1. The Main part of campus is defined as the campus bounded by University Avenue, SW 13th Street, Archer Road, and SW 34<sup>th</sup> street.

13.7.2. All pits or trenches left open overnight or unattended must be barricaded with caution lights and a plate placed over the opening. A ¼" steel plate or a plywood sheet of sufficient size and thickness may be used for this purpose. In road openings, only a steel plate with sufficient traffic-bearing strength shall be allowed, and in this case barricades are still required. Shoring must be employed in the event of unstable soil conditions.

## **14. Aerial Pathways**

14.1.1. The University of Florida does not allow aerial facilities to be placed on any building.

## 15. Underground Pathways

15.1. **ENCASEMENT:** Steel-casing pipe provides an effective housing for underground conduit. The preferred method of installing steel casing pipes is simultaneous boring and jacking. Pipe used as casing pipe must be new welded steel pipe. The pipe must conform to ASTM specifications A139, Grade B, and have minimum yield strength of 35,000 pounds per square inch. The contractor must leave sufficient clearance between the top of the conduit formation and the upper arch of the casing pipe ( 5% of casing diameter). Excavating the earth face in front of the casing by means of a water jet, or the use of water to lubricate the exterior of the casing pipe is not permitted. The diameter of the bored hole must not exceed the outside diameter of the casing pipe by more than one (1) inch. If for any reason a bore cannot be completed, the casing must be abandoned in place and filled with concrete. Duct capacity of casings using PVC schedule 40 conduits are 18" casing w/ 1/4" walls, 7-4" "C" plastic ducts. 24' casing w/ 3/8 walls, 14-4" "C" plastic ducts.

15.1.1. All soil augured from the casing pipe should be removed from the jacking pit, leaving only undisturbed earth. 5' x 5' concrete footings, which rest on undisturbed earth at each end of the casing pipe, must be constructed. Both the jacking pit and the target pit must be backfilled with well-compacted granular material (processed stone or gravel) to the elevation of the conduit. The backfill material must be placed in lifts of no more than 6 inches and each lift must be mechanically compacted. Processed stone or gravel of the following classes is acceptable for this purpose:

CLASS I - Angular 3/4 inch to 1/4 inch graded stone

CLASS II - Coarse sands and gravel with maximum particle size of 3/4 inch.

## 15.2. **Trenching, Backfilling and Compaction:**

15.2.1. **Sand:** Clean, hard, uncoated grains free from organic matter or other deleterious substances. Sand for backfill shall be mortar sand grade with 95% passing a No. 8 sieve, and not more than 8% passing No. 10 sieve.

15.2.2. **Gravel:** Clean, well-graded hard stone or lime rock gravel, free from organic material. Size ranges acceptable from No. 4 screen retention to 1".

15.2.3. **Earth:** Free of stones, wood, roots or rubbish.

15.2.4. **Backfilling:** Deposit earth or sand, depending on the type of trench requirements, carefully in 4" layers, maintaining adequate side support. Compact fill in 4" layers to meet 95% Modified Proctor Test, using mechanical means up to

the top elevation of the conduit and 12" layers to finish grade. Replace surface to the original condition, i.e., sodding in main campus areas, and seeding in the outer areas of campus. Physical Plant Division Grounds shall assist in determining sod or seed.

15.2.5. **Identification:** Provide identifying metalized plastic warning tape above conduit. Warning tape shall be placed 6" minimum and 18" maximum above the conduit.

15.2.6. **Identification Tape:** Polyethylene 0.004" thickness minimum, with metalized locator, 6" wide, yellow or green in color, black letters indicating "Telephone" or "Communications."

15.2.7. **Excavation:** Excavation shall be maintained in satisfactory condition during the progress of the work. Sub-surface structures must be constructed in adequately sized excavations with de-watering equipment installed and properly maintained where necessary. In all cases, to protect materials and personnel from injury, shoring must be employed in the event of unstable soil conditions. The standard depth of all trenching is 30 inches as measured from the top of the topmost conduit to the ground line.

15.2.8. The contractor shall at all time keep the construction area, including storage areas used, free from accumulation of waste material or rubbish. The contractor must exercise reasonable care to prevent construction debris and excavated material from washing into University storm drains. Upon completion of the construction, the contractor shall leave the work and premises in a clean, neat and workmanlike condition, satisfactory to the University.

15.2.9. **Restoration:** All non-paved surfaces (grass, sod, gravel, etc.) must be restored within 7 days of backfilling and compaction.

15.2.10. **Sidewalks:** Sidewalks thickness is 6" with 6x6 number 10 reinforcement wire, 1/2" reinforcement bar and 3000-psi concrete. Removal of sidewalks must be from expansion joint to expansion joint. Sidewalk width should be a minimum of 5 feet, and should match surrounding sidewalk patterns and widths. A float, trowel, and light broom finish is standard.

15.2.11. **Sod:** The standard sod for the University is St. Augustine, Bitter Blue or Floratan.

15.2.12. **Service Drives:** Service drives shall have an 8-inch base of Florida lime rock compacted to 95% of maximum density. Paving should be 2-inch (min.) type S-1 asphalt. Cuts made through any paved surface must be repaired in a non-discernible fashion. Cuts through concrete must be repaired by replacing the section between the nearest two joints - either construction or expansion. Cuts through asphalt must be repaired so that depressions or humps do not develop



during the warranty period. If depressions or humps develop, they shall have to be re-worked until corrected. When cuts extend through pavement markings, the replaced pavement shall be marked to match the existing pavement.

### 15.3. **PAVING AND SURFACING:**

15.3.1. **Technical Specifications for Construction and Materials:** Construction procedures must follow the usual practices of the Florida Department of Transportation for work of similar character and extent. The provisions and specifications of Division II and Division III of the "Standard Specifications for Road and Bridge Construction," Florida Department of Transportation edition of 1986 shall apply, where applicable, except where modified herein or specifically designated otherwise. References to compensation do not apply. Where reference is made to the "engineer," substitute the appropriate representative of Physical Plant Division or OIT.

15.3.2. The contractor must adequately and fully protect all parts of his work against damage until completed and accepted by UF for maintenance. The contractor at no additional expense to must properly repair damages there to UF.

15.3.3. The contractor must protect exposed surfaces adjacent to the work from physical damage resulting from construction activities and from becoming stained during application of paving materials. The contractor shall clean, repair, or replace, as required, surfaces damaged during the course of the work at no additional expense to UF.

15.3.4. The contractor must provide temporary barricades, properly lighted, to keep traffic off the work throughout the duration of the contract.

15.3.5. **Site Work:** Preparation of a new paved road over a new base course:

15.3.6. Prepare lime rock base as detailed in the Florida DOT Specifications: Allow additional lime rock for compaction of minimum 6" lime rock base prior to paving. This is to be in addition to compaction as required in the Florida DOT Specifications.

15.3.7. Asphalt Concrete Surface Course: Surfacing must consist of Type S-3 asphalt concrete in a 1/2" finishing course following the tack course.

15.3.8. **Restoration:** All roads, streets, sidewalks of concrete or asphalt construction must be restored or repaved within 3 days from the time of backfilling and compaction.

15.3.9. Newly poured concrete roads, streets, curbs, or sidewalks must be protected AND guarded from graffiti from passersby until the concrete has sufficiently cured to resist such molestation. Failure to prevent molestations (graffiti) shall result in

the new concrete having to be removed and replaced. This requirement shall warrant the contractor in taking the necessary steps in preventing such incidents, which shall include guarding the project after hours.

15.3.10. **Conduit:** PVC Conduit and Fittings: Conduit must be made of poly-vinyl-chloride, PVC schedule 40 pipe. Solvent weld fittings are to be used and joints must be watertight. All conduits must be provided with a sequentially marked pulling tape in English or metric markings with a minimum of 1200 lbs. pulling tension. Conduit must be thoroughly cleaned after lying. During construction and after the conduit is completed, the ends of the conduits must be plugged. After the conduit line has been completed, a mandrel not less than 10" long, having a cross-section approximately  $\frac{1}{4}$ " less than the inside cross-section of the conduit shall be pulled through each conduit, after which a stiff bristle brush shall be pulled through.

15.3.11. **Conduit Formation:** Where practical, conduit formations using single-bore conduit should be arranged so that orderly cable racking can be accomplished within the maintenance hole or handhold and that minimum changes are made in the formation as it enters the maintenance hole. Ducts must terminate in maintenance holes or handholes in a manner that is conducive to orderly cable racking. Main conduit formations shall enter the end walls of a maintenance hole as nearly equidistant between the floor, roof, and sidewalls as is practical. Subsidiary conduit (the additional ducts required for housing cables that would extend from the main conduit system) to a building location shall be located on top of the main conduit formation. Conduit formations that are to terminate in 4' x 4' x 4' HR handholes must splay before reaching the handhold and enter the end walls near the sides.

15.3.12. **Bends:** The contractor must use the longest radius bends possible. The minimum bend radius to be used on main conduit formation is 15 feet and on subsidiary conduit is 6 feet. These minimum radius bends must also be encased in concrete along the full length of the bend.

15.3.13. **Terminating Conduit:** The practice of terminating conduit (most often subsidiary duct) in the sidewalls of maintenance holes or handholes is not acceptable but, in certain situations, a variance may be given. The contractor must contact the OIT Infrastructure Group to obtain a written variance. In this case, the holes for the ducts must be positioned near the upper end-corner of the sidewall and then core-bored. All handhold and maintenance hole designs in this document can accommodate such locations due to the absence of rebar in this area.

15.3.14. **MAINLINE CONDUIT SIZING:** Mainline conduit is defined to be the conduit supporting feeder cables that serve buildings and other structures. Lateral or subsidiary conduits are routed from the mainline conduit system to each building, structure, and fiber interface cabinet or communications cabinet. Sizing is defined as the determination of the number of conduits to be placed between maintenance holes, handholes or to the buildings along the route.

15.3.15. A full sized 4" conduit shall be used for all installations.

15.3.16. Consider the following for sizing:

- Initial copper cable placement.
- Initial optical fiber placement.
- Initial energy, fire and security cable placement.
- Future growth in all cable systems (voice, data, video, and energy management).
- Maintenance conduit needs.

15.3.17. A mainline conduit system is allocated to have one 4" conduit for each of the following categories, some of which shall be equipped with four 1" innerducts. Depending on the immediate use of the conduit system under design, only one (1) 4-inch conduit shall be required to be equipped initially with innerducts and/or tube cable during construction. Future innerduct and/or tube cable installation shall be necessary as the need develops. The following are mainline conduit allocations:

- Initial fiber placement for voice with four 1" innerducts.
- Initial UFIntraNet and Cox Cable placement for coaxial cables with three 1¼" innerducts.
- Initial UFIntraNet and Energy Management Control System (EMCS) Network placement with four 1" innerducts.
- Copper telephone cable, no innerducts.
- Maintenance duct, no innerducts.
- Growth, no innerducts.

15.3.18. Total: six 4" conduits, of which two (2) full sized conduits are equipped with innerducts. This would be the ultimate configuration of mainline conduit.

15.3.19. Lateral conduit to a BellSouth fiber optic interface or fiber hub location shall consist of four (4) full sized conduits. One (1) conduit shall be for fiber cable equipped with four 1" innerducts, unless the fiber hub is within 30 feet of the handhold or maintenance hole and having no more than one 90-degree bend.

15.3.20. Lateral conduit to a communications cabinet shall consist of five (5) full-sized conduits. One (1) conduit is equipped with four 1" innerducts, unless the fiber hub is within 30 feet of the handhold or maintenance hole, and having no more than one 90-degree bend.

15.3.21. Future innerduct and/or tube cable installation will be necessary as the need develops and shall be the responsibility of the department or project needing the additional facilities.

15.3.22. **Innerducts:** Innerducts used on campus must conform to standard C.I.S. 4-86, which is a standard specification for corrugated innerducts produced to I.P.S. dimensions.

15.3.23. This specification establishes the parameters common to polyvinyl chloride (PVC) and polyethylene (PE) innerducts.

15.3.24. Caution must be taken to use only polyvinyl chloride (PVC) innerduct in building entrance conduit.

## **16. Vaults and Pedestals**

16.1. **Maintenance hole / Handhole:** Maintenance holes are recommended for roads, streets, parking lots and where a less obtrusive surface structure is desired. A 30" cast iron lid is less noticeable and safer than a 4' x 4' or 4' x 6' steel plate.

16.2. **Pre-cast:** Contractors are encouraged to use pre-cast handholes/maintenance holes wherever possible. Pre-cast maintenance holes or handholes shall be in compliance with NEC Article 314-55. Handholes must have concrete floors equipped with French drains, cable racks, pulling eyes, supports and miscellaneous fittings. All metal hardware must be hot-dipped galvanized. All handholes and their associated covers must be rated as traffic bearing, i.e., maintenance holes and handholes designed to withstand a subsurface water table depth of 3½ feet and H20 traffic loading. Pre-cast maintenance hole/handhold designs must be in accordance with the requirements set forth by the American Association of State Highway and Transportation Officials. This requires reinforcing bars in all floors and walls (grade 60 reinforcing steel) and 4000 psi concrete.

16.3. Typical maintenance hole/handhold sizes used at the University are as follows.

<u>Item</u>	<u>Size</u>	<u>Chimney</u>	<u>Collar/ Cover Type</u>
Handhold	4'x4'x4'	Ground Line	Traffic bearing metal plate
Handhold	4'x6'x4'	Ground Line	Traffic bearing metal plate
Maintenance hole	6'x12'x7'	24" Minimum Headroom	30" Traffic bearing ring and cover
Maintenance hole	6'x9'x7'	24" Minimum Headroom	30" Traffic bearing ring and cover

16.4. **CAST-IN-PLACE:** All cast-in-place maintenance holes and handholes must be equipped with cable racks, pulling eyes, supports and miscellaneous fittings. All metal hardware must be hot-dipped and galvanized. All maintenance holes and handholes and their associated covers must be rated as traffic-bearing, i.e., maintenance holes and handholes designed to withstand subsurface water table at a depth of 3½ feet and H20 traffic loading requirements set forth by the American Association of State Highway and Transportation Officials (AASHTO) HB-11th Edition, 1973. This requirement requires deformed reinforcing bars in all floors and walls (grade 60 reinforcing steel) and 4000 psi concrete.

16.4.1. All maintenance holes must be equipped with a 24" high collar, 10" high frame, and a 30" frame and cover. The collar shall be constructed of brick and mortar to allow for easier future level modifications and adjustments. All handhold/maintenance hole covers must be stenciled with "Communications" and be equipped with a hole or other device for cover extraction. Handhold cover plates shall be constructed of steel with an anti-skid design and be traffic-bearing. The handhold shall be equipped with a recessed metal ring to accept and cradle the cover.

16.4.2. Typical maintenance hole/handhold sizes and racking requirements to be used at the University are the same sizes listed for **pre-cast**.

16.4.3. There will be times when access to an existing conduit formation is necessary. An intercept maintenance hole/handhold would then be placed over the existing conduit formation. The new hole must be located so as to allow the existing conduit to parallel the length of the hole along one side. This allows the cables to be formed and racked along the wall once the conduit casing has been carefully removed within the boundary of the hole.

16.5. **Construction Points:** Concrete with 28-day compressive strength of 4000 psi. Reinforcing steel with yield strength of 60,000 psi grade 60. Reinforcing bars with kinks or bends are not to be used except where bends are specified. Reinforcing bars should be clean and free of loose rust, oil or other matter that might weaken the concrete-metal bonding. Forms for cast-in-place maintenance holes should be designed to permit easy removal, constructed to conform to the required maintenance hole dimensions, substantially leak-proof, and capable of being placed and secured to prevent displacement while concrete is being poured.

16.5.1. The concrete for the handhold/maintenance hole floor should be poured in a continuous operation with a plastic waterstop placed in the construction joint between the floor and walls. The concrete for the walls should be poured in a continuous operation. If it is not possible to complete the walls in one (1) pour, a construction joint with a continuous plastic waterstop must be formed. Both handholes and maintenance holes shall have concrete reinforced floors as detailed in attachment drawings. However, maintenance holes shall have a solid leak-proof floor with a sump depression while a handhold shall have a "sump like" hole used as a French drain complete with coarse gravel.

16.5.2. When pouring, do not place concrete in contact with the earth walls of the excavation. Close sheeting placed to support the earth wall may be used as forms for the outside surfaces of the maintenance hole walls. Specially constructed outside forms may also be used.

16.5.3. To raise the cast-iron frame and maintenance hole cover to the proper height above the maintenance hole, some combination of pre-cast concrete collars of various heights, i.e., 3, 9 and 15 inches, may be used. The frame and each

collar must be set in mortar at the top of the maintenance hole or on another collar. The frame shall be set on a collar constructed of bricks or concrete segments and mortar.

16.5.4. Temperature reinforcement has been designated as #5 rebars with nominal 12-inch spacing. No. 5 rebars must be run parallel to the floor-wall, and wall-wall junctions to provide a means for fully tying the end of the rebars together to form an electrical grid. No. 14 annealed steel wire should be used to make wire ties for the rebar. Welding of the bars is not permitted. The rebars must extend to a point 1 to 2 inches from the outside edge of the concrete slabs. All concrete slabs shall have reinforcement in two (2) directions. Rebars for the floor slabs are designated as "W" and "L" reinforcement, and those for the wall slabs are designated as "H" and "L" or "H" and "W." The "H" reinforcement is placed parallel to the height (H) dimension, the "W" reinforcement parallel to the width (W) dimension, and the "L" reinforcement parallel to the length (L) dimension. The reinforcement in one (1) direction also has an "I" designation. The "I" indicates reinforcement which must be located nearest the inside surface of the slab, 1" minimum from the inside surface of roofs and walls and 3" for floors. The other reinforcement must be located next to the "I" reinforcement and toward the outside surface of the slab.

16.5.5. A diagonal pattern of rebars must be placed around all openings in slabs except where single duct subsidiaries can be located between the reinforcement. The diagonal reinforcement should consist of #5 rebars placed at 45 degrees to the slab sides and, where practical, extend to within 1 to 2 inches of the exterior slab edges. The first diagonal is placed 2" from the edge of the opening and each succeeding parallel bar is located 3 to 4 inches on center away from the opening. Diagonals located between the openings should extend uninterrupted to the slab edges to provide additional structural integrity to the slab.

16.6. **Cable Bonding:** A cable bonding ribbon must be provided in the center of each splicing bay of the maintenance hole/handhole. The bonding ribbons should be included in the roof slab in the case of a maintenance hole clamped to one of the reinforcement bars or to a reinforcement bar in the wall in the case of a handhold. One continuous length of bonding ribbon can serve two (2)-splicing bays on opposite walls. The bonding ribbon should be run within the wall slab and brought into the maintenance hole at a point approximately 3" below ceiling level.

16.7. **Pull-in-Irons:** Pulling-in irons are required as a point of attachment for blocks, sheaves, etc., to place and remove cables. The pulling-in iron must be installed to extend into the handhold with a clear opening of 3". One (1) pulling-in iron is placed opposite and in line with the centerline of each duct entrance formation and a minimum of 3" above the floor.

16.8. **Conduit Lengths:** Conduit section lengths (the measured distance between two 2 holes) must never exceed 700 feet with any more than two 90-degree sweeps allowed in a conduit section. A full 180 degree sweep (full reversal in

direction) is definitely not permitted without a maintenance hole or handhold inserted within the sweep.

**16.9. MAINTENANCE HOLE AND HANDHOLE SIZING:** Several factors determine when a maintenance hole or handhold is to be installed.

16.9.1. Maintenance holes are recommended over handholes when the total number of 4" conduits to be terminated in the walls exceeds twelve. The total number of conduits terminated in a handhold or maintenance hole is determined by counting all conduits terminated in the "end" and "side" walls.

16.9.2. A 4' x 4' x 4' size handhold can be used to support up to eight 4" conduit terminations, only if copper telephone cables of 200 pair or less are to be spliced in the hole.

16.9.3. A 4' x 6' x 4' handhold can be used to support up to twelve 4" conduit terminations and can support copper telephone cables exceeding 200 pairs.

16.9.4. When a situation calls for a special size and shape maintenance hole and one of the four (4) sizes cannot be used, OIT shall design the maintenance hole and provide drawings.

**16.9.5. COMMUNICATIONS CABINET:** Communications cabinets provide an above ground cabinet facility for cable terminations and electronic equipment placement. The communications cabinet is mounted on a concrete slab for stability and weed control. The cabinet has hinged doors on both sides for easy access to the internal mounting surfaces. The hinges consist of a continuous hinge using galvanized steel with a stainless-steel pin. The doors are equipped with two 3-point latching mechanisms operated by padlocking handles. The cabinet is made of 12-gauge galvanized steel with a drip-shield top and smooth, seam-free sides which slope front to back to prevent rain from entering the cabinet. The cabinet is painted BellSouth light green

**16.9.6. BLUE LIGHT PHONES:** The location of blue light phones is to be coordinated with the University Police Department. The University recognizes one construction type and two models. This type is of metal construction and is typically referred to as Code Blue. This type shall require a constant 110-volt AC source and telephone cable.

16.9.7. Blue light phones are typically located exterior to buildings, either wall-mounted at building entrances or away from the building in the parking areas in a free standing configuration. PVC conduit is placed for both the power and telephone service to the units. Outside-type telephone cable is required for this type of installation. Outside telephone-station cable is shielded and filled with water-resistant compound with two to five pairs. There are several modes of Code Blue. A wall-mounted unit is used for building entrance locations and a unit for free



standing installations is utilized away from buildings. A special concrete base is needed for the Code Blue unit for freestanding applications. Again, outside type telephone cable is required for free standing applications.

16.10. Final inspection of Blue light phones shall be done by OIT Infrastructure.

16.11. **Physical Security:** All new maintenance holes/ handholes shall have locking type lids to ensure the security of the University's outside plant resources.

## **17. Appendix #1 - UF Labeling and Naming Conventions in Accordance with ANSI/TIA/EIA-606-A**

17.1. **Introduction:** The new administration standard as presented in the ANSI/TIA/EIA-606-A addresses the need for an independent and scalable labeling standard in the administration of telecommunications cabling infrastructure. In order to standardize and administer the entirety of the infrastructure at the University of Florida, it is necessary to have a complete standard for labeling so that technicians do not need to learn new standards as they move from one building to the next. Contractors need a concrete labeling scheme furnished to them so that they can make their products as useful as possible.

17.1.1. According to the ANSI/TIA/EIA-606-A standard, what we are presently concerned with would be considered a class 3 labeling standard. We have multiple buildings and outside pathways that must be documented. All identifiers are independent and scalable. All labels read from the general to the specific from left to right.

17.1.2. There are three significantly different pieces to consider in developing a system for the administration of any complex system: naming, labeling, and supporting documentation.

17.2. Naming is the process of assigning every piece of identifiable equipment a unique identifier to differentiate it from others. Unique names enable the use of databases in administration of the supporting documentation. In this system, the style of a name differs based upon the type of equipment named. This allows a quick and easy identification of the hardware.

17.3. Labeling is the process of affixing tags to the hardware so that their names can be determined. The tag affixed to the hardware is not always the full name of the piece of infrastructure. As will become apparent later, a number of pieces of a name can be determined based upon the location of the hardware. Because of this, it is not necessary to affix the entire name to every piece of hardware. This distinction becomes critical when the piece of equipment is too small to accept a label that contains its full name.

17.4. Supporting documentation is the key to any successful administration. Naming and labeling assure that everyone on campus can use the same basic keys for accessing information about the infrastructure but the supporting documentation holds all the information that individuals will need to know: fiber-optic strand count, termination points, last test date, copper pair counts, manufacturer of the cable and so on. This document deals primarily with the naming and labeling process in order to support contractors installing the network infrastructure here at the University of Florida. Aside from the deliverables

required by UF Telecommunications Standards, the contractor is not responsible for maintaining any documentation of campus infrastructure.

17.5. **Naming:** There are four distinct styles of naming telecommunications infrastructure here at the University of Florida. They all use the same identifiers in the construction of a name but differ in their order and presentation.

17.5.1. Every component of the telecommunications infrastructure has a unique and independent identifier.

Label Target	Example	Explanation
Building	0115	University of Florida official building number
Telecommunications Room	1A	1-first floor, A- Telco Room A on that floor
Communications Cabinet	PCB001	Designates Pathway communication cabinet #1
UTP communications panel	A	Designates communication panel A
Other communications panel	1	Designates communication panel 1, most commonly a fiber panel
Panel module	1	Module #1 in a communication panel
Port	1	Port #1 in a module or communication panel

17.5.2. Individual identifiers can be combined to create an overall and accurate picture of a cabling plant. Names will use a combination of these identifiers in an established format to completely identify any piece of the cabling plant. This, in turn, requires that every piece of equipment be labeled so that a technician can determine the name of any piece of infrastructure while in the field.

17.6. **Constructing a name (location):** There are four fundamental identifier types that shall be used at the beginning of any name: building numbers, telecommunications room identifiers, room numbers, and communications cabinet identifiers. These are used to designate locations and include all location types here at the University of Florida. Assignment of any location identifiers should be coordinated with Facilities Planning & Construction in the case of building and room numbers, or the Office of Information Technology (OIT) in the case of Telecommunication Room (TR) identifiers or Communications Cabinet identifiers.

17.7. **Building numbers:** The University of Florida has determined official building-number designations for each building on and off campus. These numbers shall be used to reference the buildings in all names. These numbers can be obtained from UF's Department of Facilities Planning & Construction. For

example, 0042 is the official building number of the Computer Sciences and Engineering Building.

17.8. Telecommunication Room Identifiers: Each Telecommunication Room (including Entrance Facilities and Main Telecommunications Rooms) shall be identified with two alphanumeric characters that represent the floor level and a letter that differentiates it from other TR's on the same floor. The identification, assignment of these identifiers, and labeling of these rooms will be covered later in this standard. The full name of a Telecommunications Room is this two-character identifier preceded by the four digit building number. For example, 0038-1A is the name of a TR on the first floor of building 0038 (Bryant Hall). All letters in TR identifiers are capitalized.

17.9. Room Numbers: Room numbers are assigned by the University and reflect individual rooms that are not serving as TR's. Due to the mutable nature of room numbers their use in the labeling is limited but they can be referenced in the supporting documentation and used in optional labels. The full name of any room is the official room number preceded by the four digit building number. For example, 0038-230 is room 230 in building 0038 (Bryant Hall). All letters in room numbers are to be lower-case to assist in differentiating them from similar TR identifiers.

17.10. Communications Cabinets: UF maintains a system of externally located Communications Cabinets. These have been assigned sequential numbers based upon date of installation. The letters PCB precede these numbers. For example, PCB048 is a Communication Cabinet located at the north end of Fraternity Row.

17.11. **Constructing a name (equipment)**: All infrastructure elements that are not addressed in the other naming standards are named as pieces of infrastructure equipment. The beginning of the name specifies the location of the piece of equipment. The end of the name includes a three-letter description of the equipment and ends with an index number. The index number exists solely to differentiate the piece of equipment from other similar equipment in the same location. The three-letter acronym used in describing the equipment is based on the abbreviations presented in the ANSI/TIA/EIA-606-A. The most common abbreviations used at the University of Florida can be found in the following examples.

0047-1A-PRK1

- This equipment is located in Building 0047, Telecommunications Room 1A.
- This equipment is a pathway element (P), specifically, a rack (RK).

- The index number will differentiate it from other racks in the same location, a second rack in building 0047, room 1A would have an index number of two.

0047-1A-TGB1

- This equipment is located in Building 0047, Telecommunications Room 1A
- This equipment is a telecommunications (T) grounding bar (GB)
- The index number will differentiate it from other grounding bars in the same location; a second grounding bar would have an index number of two

0047-235a-WAO01

- This equipment is located Building 0047, room 235a
- This equipment is a Work Area Outlet (WAO)
- The index number will differentiate it from other work area outlets in the same location; a second work area outlet in the same room would have an index number of two

17.12. An exception to this is the Telecommunications Main Grounding Busbar. It does not have an index number at the end of its name since there should never be a situation where there will be more than one per building. Instead, an additional alphabetic identifier is used.

0047-1A-TMGB

- This equipment is located Building 047, Telecommunications Room 1A
- This equipment is a telecommunications (T) main grounding bar (MGB)

17.13. Pieces of equipment that are located in racks or mounted on walls follow a similar naming convention with an additional character to denote where the equipment can be found. This additional character follows the second dash and precedes the three-letter descriptive acronym. All acronyms are based on ANSI/TIA/EIA-606-A standard abbreviations. The additional character shall be a number if the equipment is located in a rack or other identified termination area (rack, cabinet, mounting table, and so on). This number shall be the index number of the termination location. If the equipment is wall-mounted, the character shall be an upper case W.

0047-1A-1FPL1

- This equipment is located in Building 0047, Telecommunications Room 1A.
- This equipment is located or mounted inside a termination area (rack, cabinet or other) within the room identified as #1.

- This piece of equipment is a fiber (F) panel (PL) and its index number is 1.

0047-1A-WXPL1

- This equipment is located in Building 0047, Telecommunications Room 1A.
- This equipment is mounted on the wall.
- This piece of equipment is a coaxial (X) panel (PL) and its index number is 1.

17.14. An exception to these rules has been made in the case of Unshielded Twisted Pair (UTP) termination panels. Instead of using index numbers, UTP panels are identified by an indexing letter. This is in accordance with the standards set out by the ANSI/TIA/EIA-606-A.

0047-1A-WCPLA

- This equipment is located in Building 0047, Telecommunications Room 1A.
- This equipment is mounted on the wall.
- This piece of equipment is a copper twisted pair (C) panel (PL) and its index letter is A. A second panel on the wall would be identified as B.

17.15. Subdivisions of pieces of equipment, such as the modules of a fiber panel or the ports of a UTP panel, will have the same name as their parent piece of equipment followed by an additional index number that is assigned to the subdivision. In the interest of brevity, subdivisions are not preceded by a three-letter descriptor. The index number of the parent piece of equipment and the subdivision will be separated by a period. A period always represents a subdivision of a larger piece of equipment. This nomenclature applies to all aspects of this naming standard except when referring to the ports on an individual module – In that case, the two numbers will be separated by a slash, instead of a period, following current switch naming conventions. (Switch naming conventions can be found at

[https://net-services.ufl.edu/network\\_information/documents/naming.html](https://net-services.ufl.edu/network_information/documents/naming.html))

17.16. Port numbers are assigned beginning with 1 independently for each subdivision

0047-1A-WCPLA .01

- This equipment is located in Building 0047, Telecommunications Room 1A.
- This equipment is mounted on the wall.
- This is the first port of a UTP copper(C) panel (PL) designated as A.

- In general, UTP panels do not have subdivisions aside from ports.

#### 0047-1A-1FPL1.2

- This equipment is located in Building 0047, Telecommunications Room 1A.
- This equipment is located or mounted inside a termination area (rack, cabinet or other) within the room identified as #1.
- This piece of equipment is part of a fiber (F) panel (PL) whose index number is 1.
- This equipment is a module designated as module #2.
- In general, fiber optic panels are assumed to have subdivisions (modules or drawers) that will be identified. Fiber Panels that do not have modular subdivisions are treated as if all ports are located in module #1.

#### 0047-1A-1FPL1.2/03

- This equipment is located in Building 0047, Telecommunications Room 1A.
- This equipment is located or mounted inside a termination area (rack, cabinet or other) within the room identified as #1.
- This piece of equipment is part of a fiber (F) panel (PL) whose index number is 1.
- This designates port #3 on module #2 in fiber panel #1.

17.17. Note that the standard for identification of a Communications Cabinet follows the same standard as any other piece of equipment. It has a three-letter descriptor followed by an indexing number. Since they are not located inside any traditional space, they have no location numbers to precede them and their location is tracked in the supporting documentation held by OIT.

17.18. **Constructing a name (backbone cables and pathways):** Backbone cable and pathway names are constructed by combining the names of the two Telecommunications Rooms that are being joined by this equipment, following them with a description of the equipment itself and ending with a numeric designator to distinguish the equipment from any other object with the same qualities. Order of the telecommunications rooms in the name is decided alphanumerically, not based on physical location itself. The Telecommunications Room identifiers will be separated by a slash and followed by a comma to separate them from the equipment description. There is no space between the comma and the building description.

17.19. The following is a breakdown of a single-mode fiber cable name.

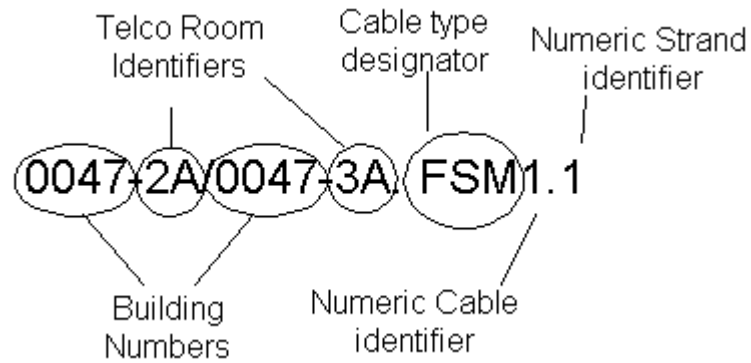

17.20. Below is a breakdown of a composite fiber (containing both multi-mode and single-mode) cable name

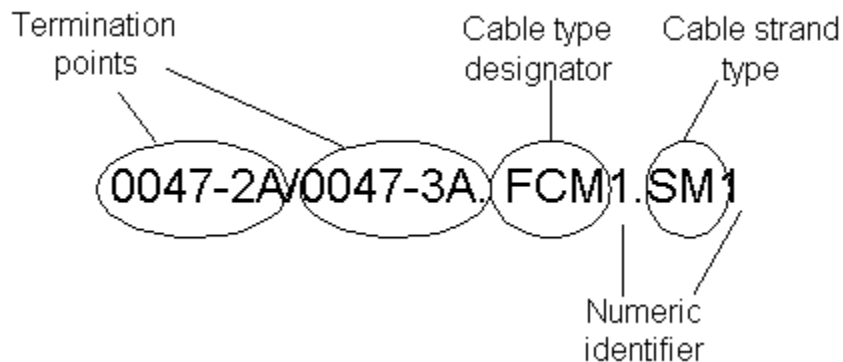

17.21. Consistent with this standard, index-number identifiers for cables and cable strands are used solely to differentiate themselves from other cables sharing their same characteristics. A cable should only be identified with a 0047-1A/0193-1A,-FMM2 if there is already a 0047-1A/0193-1A,-FMM1 in existence.

0047-1A/0193-1A,FMM1

- Cable terminates in Building 0047, Telecommunications Room 1A.
- Cable terminates in Building 0193, Telecommunications Room 1A.
- This is a fiber (F) multimode (MM) cable connecting these rooms and it's index number is 1.

0047-1A/0193-1A,FSM1

- Cable terminates in Building 0047, Telecommunications Room 1A.
- Cable terminates in Building 0193, Telecommunications Room 1A.



- This is a fiber (F) singlemode (SM) cable connecting these rooms and it's index number is 1.

0047-1A/0193-1A,FCM1

- Cable terminates in Building 0047, Telecommunications Room 1A.
- Cable terminates in Building 0193, Telecommunications Room 1A.
- This is a fiber (F) composite (CM) cable connecting these rooms and it's index number is 1.

0047-1A/0193-1A,CUT1

- Cable terminates in Building 0047, Telecommunications Room 1A.
- Cable terminates in Building 0193, Telecommunications Room 1A.
- This is a copper (C) unshielded twisted-pair (UT) backbone cable connecting these rooms and its index number is 1.

0047-1A/0047-1A,CUT1

- Both ends of cable terminate in Building 0047, Telecommunications Room 1A.
- This is a copper (C) unshielded twisted-pair (UT) backbone cable
- This is representative of a backbone cable connecting a wall mounted 110 block to a rack mounted 8P8C patch panel

0047-1A/0193-1A,PCO1

- Conduit terminates in Building 0047, Telecommunications Room 1A.
- Conduit terminates in Building 0193, Telecommunications Room 1A.
- This is a pathway (P) conduit (CO) connecting these rooms and it's index number is 1.

0047-1A/0193-1A,TBB1

- Conductor terminates in Building 0047, Telecommunications Room 1A.
- Conductor terminates in Building 0193, Telecommunications Room 1A.
- This is a telecommunications (T) bonding backbone (BB) cable connecting these rooms and it's index number is 1.

17.22. Subdivisions of backbone cables or pathways shall be labeled following the manner of labeling subdivisions in equipment. Subdivisions will have the same name as their parent piece of equipment followed by an additional index number that is assigned to the subdivision. (Note: different binder groups in UTP or fiber cable will not be tracked as subdivisions in this standard.) In the interest of brevity, subdivisions are not preceded by a three-letter descriptor except as needed to differentiate themselves from other subdivision types. Currently, only

composite-fiber-cable subdivisions require an additional descriptor for each fiber strand. The index number of the parent piece of equipment and the subdivision will be separated by a period. Fiber strand numbers in a fiber cable will be assigned in order with standard color code as outlined in ANSI/TIA/EIA-598-A

0047-1A/0193-1A,FMM1.01

- Cable terminates in Building 0047, Telecommunications Room 1A.
- Cable terminates in Building 0193, Telecommunications Room 1A.
- This is strand #1 in fiber (F) multi-mode (MM) cable #1 connecting these rooms

0047-1A/0193-1A,FSM1.01

- Cable terminates in Building 0047, Telecommunications Room 1A.
- Cable terminates in Building 0193, Telecommunications Room 1A.
- This is strand #1 in fiber (F) single-mode (SM) cable #1 connecting these rooms

0047-1A/0193-1A,FCM1.MM01

- Cable terminates in Building 0047, Telecommunications Room 1A.
- Cable terminates in Building 0193, Telecommunications Room 1A.
- This is multi-mode strand #1 in fiber (F) composite (CM) cable #1 connecting these rooms.
- Single-mode strand #1 of the same cable would be named 0047-1A/0193-1A, FCM1.SM1.

0047-1A/0193-1A,CUT1.01

- Cable terminates in Building 0047, Telecommunications Room 1A.
- Cable terminates in Building 0193, Telecommunications Room 1A.
- This is a pair #1 in copper (C) unshielded twisted-pair (UT) cable #1 connecting these rooms.

0047-1A/0193-1A,PCO1.01

- Conduit terminates in Building 047, Telecommunications Room 1A
- Conduit terminates in Building 193, Telecommunications Room 1A
- This is innerduct #1 in pathway (P) conduit (CO) #1 connecting these rooms

**17.23. Constructing a name (horizontal cables and pathways):** Horizontal refers to any piece of the cable plant that feeds directly from a Telecommunications Room out to a user outlet or work area. This includes equipment that feeds out to a consolidation point in the work area or mutoa.

Horizontal cable labeling is based on the point of origination of the cable or pathway element in the Telecommunications Room. Each horizontal plant element is labeled on both ends with an identifier that locates its termination point in the appropriate Telecommunications Room.

17.24. For UTP horizontal cables, the point of origination for the cable run will usually be located in a patch panel or termination block. A port in a patch panel is named according to the standards for equipment given above. For identification of horizontal cabling, a shorthand version of the full port name is used in order to differentiate the cable name from the termination point name, and to facilitate labeling by providing a shorter name. A termination point for a horizontal run might terminate in 0047-1A-1CPLA.1. This would be port #1, in copper panel A, in termination area #1, in Telecommunications Room 1A, in building #0047.

17.25. The horizontal cable attached to that port would be identified as follows:

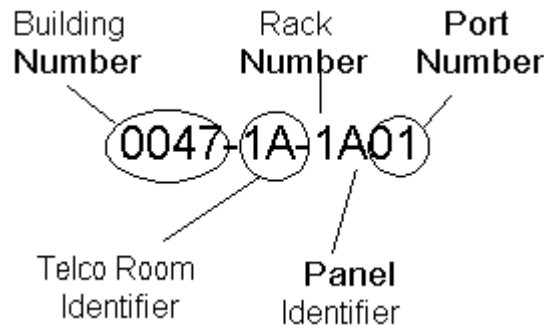

0047-1A-1A45

- UTP cable originates in Building 047, Telecommunications Room 1A.
- UTP cable originates in Rack #1, Patch Panel A, Port 45.

0047-3B-WA37

- UTP cable originates in Building 047, Telecommunications Room 3B.
- UTP cable originates in wall mounted Patch Panel A, Port 37.

17.26. For non-UTP horizontal cable installations, the panel identifier shall not be used for cable names due to the variety of termination methods that exist for non-UTP cable. Fiber cables truly terminate in more than one port and could conceivably terminate in multiple panels. Coaxial installations often do not use termination panels at all and plug directly into electrical devices.

17.27. The name of non-UTP horizontal cables is still based upon the point of origination, but that information is limited to the Telecommunication Room where

the cable originates. This information is followed by the standard three-letter descriptor and an index number.

0047-1A-FMM01

- Horizontal fiber (F) multimode (MM) cable that originates in Building 047, Telecommunications Room 1A.

0047-3B-XDR01

- Horizontal coaxial (X) drop (DR) that originates in Building 047, Telecommunications Room 3B.

17.28. Finally, horizontal conduit installations will be named following the equipment standard set forth above. This implies that a horizontal conduit will be named for the Telecommunications Room in which the conduit originates.

0155-4A-PCO01

- This is a horizontal conduit.
- This horizontal pathway (P) conduit (CO) element originates in Telecommunications Room 4A, in building #0155.

17.29. **Labeling:** Labeling is the process of affixing tags to the infrastructure components in order to effectively communicate the name of that piece of equipment to the technician in the field. In many cases this can be as simple as tagging a piece of equipment with the official name but under some circumstances this may not be feasible due to the size of the piece of equipment or other factors. Additionally, the labeling may communicate other pieces of information such as what fiber cable is located in what FPL in a particular Telecommunications Room. And finally, this standard addresses the need for each piece of equipment to be labeled in exactly the same fashion so that technicians can expect the same standards of repair to be used at each University of Florida location.

17.29.1. All labels are to be mechanically generated. Handwritten labels are not acceptable. All label adhesive shall have a functional lifespan equal to the infrastructure being labeled.

17.30. Following is a comprehensive list of how each piece of network infrastructure will be labeled at the University of Florida. If there are any questions concerning these requirements, please contact OIT.

#### 17.31. **Backbone Conduit**

An installed conduit shall be labeled with its full name as discussed in the naming portion of this standard above. The backbone conduit will be labeled at

both ends within 4 inches of termination of the conduit. The backbone conduit will also be labeled where it enters and where it exits any pull boxes that have been installed along its path.

#### **17.32. Communications Cabinet**

Communications Cabinets are to be labeled with their full name. Cabinets should be labeled outside on the most visible side. Cabinets should be labeled inside as well. The inside label will be applied to the interior of the fiber-side door with the locking assembly. Purchasing of labels for use on external Communication Cabinets must be coordinated through OIT.

#### **17.33. Entrance Facilities, Main Telecommunications Rooms and Telecommunications Rooms**

Room labeling will consist of a plastic sign on the outside door of the Telecommunications Room consistent with the style of other room signs in the building. This sign should designate the use of the room as a Telecommunications Room and display the appropriate identifier for that specific room such as 'Telecommunications Room 1A'.

#### **17.34. Fiber- Optic cable**

The fiber optic cable should be labeled at both termination points on the outside jacket of the cable within 8 inches of the breakout point for the individual strands. This label will contain the full name of the cable. A typical backbone label will be of the following format, 0147-1A/0147-3A, FSM1. A typical horizontal label will be of the following format, 0147-1A-FSM01. This label will be applied outside of the fiber panel.

17.34.1. Individual fiber strands should be inserted into any fiber panel following the standard color code for fiber with Blue being first, as per ANSI TIA/EIA-598-A. This color code should be followed so it can be read from left to right and from up to down for each module as viewed from the front of the fiber panel. In the documentation, strand numbers will begin at 1 and ascend in keeping with the color code, i.e., blue=1, orange=2, green=3, and so on.

17.34.2. Each fiber termination should be labeled on the boot by a number that corresponds to its placement in the color code of the cable. Numbers should begin at 1 and ascend from there with duplicate numbers used for different types of fiber strands in one cable. For example, a composite fiber cable will have multiple strands designated with a 1 to correspond to the first MM fiber cable and the first SM fiber cable. Numbers will not refresh for different binder groups, only for different classifications of fiber.

The color sequence to be used is:

Blue-Orange-Green-Brown-Slate-White-Red-Black-Yellow-Violet-Rose-Aqua

### 17.35. Fiber Panel

#### 17.35.1. Outside

A fiber panel should be assigned an independent identifier and be labeled with it in the upper right corner of the front of the LIU. Appropriate identifiers include FPL1, FPL2, and so on.

17.35.2. A fiber panel should have a list of all fiber cables that are held in the box itself. Often times, this will just be one fiber cable but could be much more. This list should be preceded with an introduction of 'This FPL holds:' or the like to prevent confusion between the fiber name and the recorded name of the fiber panel. This list should be in the upper left corner of the fiber panel.

17.35.3. In the event that both ends of a particular fiber cable terminate in the same room, the name of that cable on the front of the fiber panel should be followed by an additional label in parentheses that specifies the rack and fiber panel numbers on both ends of that cable. For example, 0019-2A/0019-2A,FMM1 followed by (WFPL6/1FPL1) would communicate that one end of the cable terminates in a wall mounted fiber panel labeled FPL6 and a rack mounted fiber panel labeled FPL1 in rack 1. This additional label does not add to the cable name for record purposes but exists solely to assist technicians in the field

This FPL holds: 0113-1A/0147-1A, FSM1 0113-1A/0147-1A, FMM1	FPL1
---	------

#### 17.36. Inside

17.36.1. Fibers should be installed in each module of a fiber panel from left to right and up to down accordingly as you look at the face of the bulkheads with the standard color code for fiber installation.

17.36.2. Each bulkhead will have an independent identifier. In a fiber panel that has been subdivided into modules, label the modules with numbers beginning with 1 and ascending. The individual bulkheads need not be labeled as they will be identified with numbers that begin with 1 and will be read from left to right or up to down in accordance with the orientation of the module. In fiber panels that have not been subdivided, the individual bulkheads will need to be identified with a number. If the fiber panel does not come preprinted, the installer will be responsible for labeling the bulkheads.

17.36.3. A documentation page will be supplied inside the panel that should be marked with which fiber strand matches up to which bulkhead. The installer may create a simple spreadsheet similar to that pictured below. In this case,

labeling should make clear the identity of each bulkhead and the fiber strand that is connected to it. In the case of horizontal fiber, the strand identifier will be followed by the room number of the cables remote end. This sheet should be stored in a clear plastic pouch inside the FPL. If the FPL does not provide such a pouch, the installer is responsible for providing one. Copies of this spreadsheet will be supplied to OIT with all other deliverables at the end of a project.

**Fiber Panel # 0006-2B-WFPL2**

<b>Module/Port</b>	<b>Fiber Identifier</b>
1/1	0006-2B/0406-2A, FMM1.01
1/2	0006-2B/0406-2A, FMM1.02
1/3	0006-2B/0406-2A, FMM1.03
1/4	0006-2B/0406-2A, FMM1.04
1/5	0006-2B/0406-2A, FMM1.05
1/6	0006-2B/0406-2A, FMM1.06
2/1	0006-2B-FMM01.01(Rm 0234)
2/2	0006-2B-FMM01.02(Rm 0234)
2/3	0006-2B-FMM02.01(Rm 0236)
2/4	0006-2B-FMM02.02(Rm 0236)
2/5	0006-2B-FMM02.03(Rm 0236)
2/6	0006-2B-FMM02.04(Rm 0236)

17.37. This insert can be found in fiber panel #2, mounted on the wall In Telecommunications Room 2B, in building #0006. Bulkhead #1 of module #1 holds the strand #1 of multi-mode fiber-optic cable #1 that connects Telecommunications Rooms 0006-2B and 0406-2A. Bulkhead #1 of module #2 holds the first strand of a horizontal fiber cable that feeds from Telecommunication Room 0006-2B.

17.38. At no time should the labeling inside a fiber panel require a technician or engineer to open the installer's side of the fiber panel to retrieve labeling information.

**17.39. Grounding busbars**

Each grounding busbar in each Telecommunication Room will be labeled in the upper-left corner with the full name of the busbar.

**17.40. Horizontal Cable**

Each end of the horizontal cable should be labeled on the outside jacket of the cable within 12 inches of the termination points with the name of the cable. Horizontal cables do not need building identifiers printed in the name on these labels. This label will follow the conventions outlined above with a typical label being 1A-1A03 in the case of UTP cable or 1A-FMM01 in the case of non-UTP cable. This label shall be applied before the horizontal cable enters any bundle.

#### 17.41. Horizontal Conduit

17.41.1. An installed horizontal conduit that directly connects the WAO with the TR without passing through the cable tray shall be labeled with the conduit's full name and the name of the WAO it serves within 4 inches of the termination in the Telecommunications Room.

17.41.2. An installed horizontal conduit that directly connects the WAO with the TR without passing through the cable tray shall be labeled at the user end, inside the work area outlet box with the full name of the conduit

17.41.3. WAO feeding horizontal conduit that stubs out at the ceiling or extends only from the Work Area Outlet to the nearest cable tray shall be marked inside the WAO with blue paint. Where it terminates in the ceiling or near the cable tray, this conduit shall be wrapped with blue electrical tape.

#### 17.42. Twisted Pair Patch Panels and Termination Blocks

17.42.1. Labeling of panels or punch blocks with letters will begin with A. Labeling of panels should begin again with the letter A for each new termination area and the labeling of panels on the wall should begin with A.

17.42.2. Where possible, individual ports on the panel should be numbered in ascending order. If not printed on the panel by the manufacturer, the installer is responsible for making sure that each port is labeled with its own number. Since identification of individual panels for wall mounted 110 panels can be difficult, that the installer will be held responsible for labeling all ports on wall mounted 110 blocks with the Panel identifier and the port identifier before adding additional labeling information.

#### 17.43. Horizontal terminations

Each port on a UTP termination panel will be labeled with the room number of the room where the opposite end of the cable terminates.

For rack or wall mounted 8P8C patch panels that do not have a defined label space place the label above or below the Port. E.g., *rm 424*.

For rack or wall mounted 110 punch blocks, labeling in the approved labeling section above or below the termination pins will fulfill this requirement. E.g., *A01 / rm 424*.

#### 17.44. Backbone terminations

Where 4 pair UTP cable terminating in patch panels is being used as a backbone connection between TR's, the patch panel port where they terminate will be labeled with the termination position of the other end of the cable. For example, where 0132-1A/0132-1B,CUT1 connects two TR's each patch panel would be labeled with the termination position of the other room. In 0132-1A, the port where this line terminates may be labeled 1B-1A05. This points to Rack #1, Panel A, and port 5 in TR 1B.

For higher count UTP backbone cables terminating in wall mounted 110 blocks on both sides, the termination area should be labeled with the name of the backbone cable. This should be followed by the pair count in parentheses. Pair



count should also be accessible through the supporting documentation. An appropriate label on a fourth floor termination block would read, 0024-3B/0024-4A,CUT1 (100 pair) where the other end of the cable terminates in room 324 and the cable has 100 pairs.

For higher count UTP cables that terminate in a 110 block on one side and an 8P8C patch panel on the other, we default to the standard listed above for 4 pair UTP cables. This requires that the 110 blocks be split into logical ports for purposes of labeling. Each pair, or set of pairs, that connect to a port on the 8P8C patch panel will be considered a port and should be labeled as such on the wall mounted panel. Each panel on each side then will be labeled according to the port identifier for the other side. For example, where 0132-1A/0132-1A,CUT1 connects two termination areas within the same TR, the 110 block and the 8P8C patch panel would be labeled with the termination position of the other side. On the patch panel, each port would be labeled with a port identifier for the 110 block, *1A-WA14*. On the 110 block, the 'port', or series of pairs, would be labeled with the panel and port identifier for the 110 block followed by the port identifier for the patch panel, *A14 / 1A-1A14*.

#### **17.45. Rack or other Termination Area**

Termination areas within a room should be labeled numerically beginning with 1 and ascending as more racks or cabinets are added to the room. The equipment defining the termination area should be clearly labeled along the top crossbar.

For purposes of this labeling standard, a termination area is considered to be any structure capable of holding telecommunications terminations and electronic hardware. This includes, but is not limited to, 7-ft free-standing racks, free-standing enclosures, 3-4 ft wall mounted fixed racks, wall-mounted enclosures, server desks and so on.

#### **17.46. Telecommunications Bonding Backbone**

Telecommunications Bonding backbones will be labeled with the full name of the bonding backbone at each termination point.

In addition, the bonding backbone will be labeled with the full name of the bonding backbone at every point to which it is bonded in any other Telecommunications Rooms through which it passes.

#### **17.47. Telecommunications Pull Boxes**

All pull boxes installed to support telecommunications infrastructure will be identified as such. The letters OIT will be painted on the front cover plate of the outlet box.

All conduits entering the pull box shall be labeled as addressed in the horizontal and backbone conduit sections in this standard.

#### 17.48. Twisted Pair Backbone cable

The twisted pair cable should be labeled at both termination points on the outside jacket of the cable within 8 inches of the breakout point for the individual strands. This label will contain the full name of the cable. A typical label will be of the following format, 0147-1A/0147-3A, CUT1.

#### 17.49. Work Area Outlets

Outlet box ports shall be labeled on the appropriate area with the name of the cable connected to them without the building designator. For example, the Work Area Outlet port connection for 0047-1A-1B05, should be labeled 1A-1B05. See the illustration below.

Outlet boxes will be labeled numerically with the Work Area Outlet number at the top of the faceplate preceded by WAO. For each room, this number will begin at 1 and ascend numerically as new outlet boxes are added.

The interior of an outlet box should be labeled with the name of the horizontal conduit that feeds it (see horizontal conduit section).

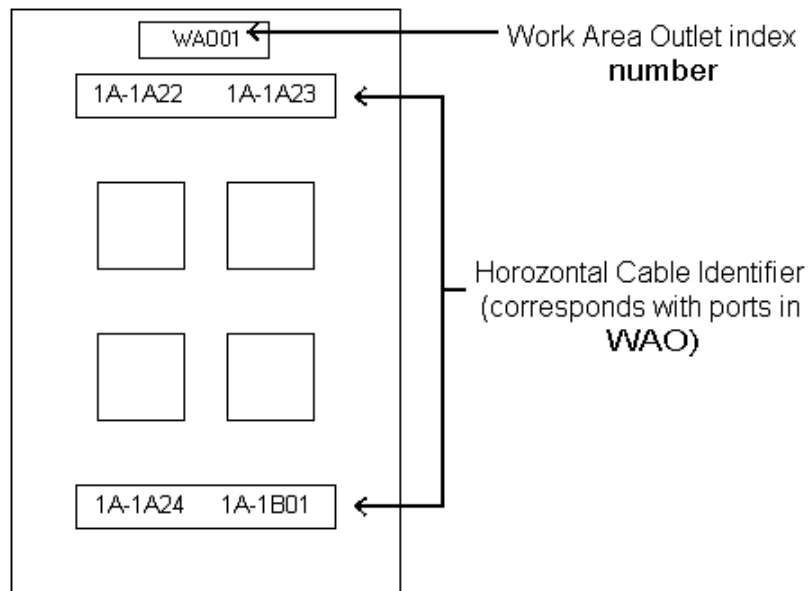

17.50. **Supporting Documentation:** All deliverables that are turned over to the University of Florida will reference network-infrastructure equipment using this standard. At that point it is the responsibility of OIT to maintain all records and documentation of network infrastructure. As such, those procedures are open to more regular review, procedural change and will not be addressed here.

17.51. **Conclusion:** This document covers the most common labeling needs for the installation of network infrastructure across the University of Florida. There are a number of more specific situations covered in the ANSI/TIA/EIA-606-A administration standard including a standard fare of abbreviations for descriptors. If you have any questions concerning these standards and their interpretation in reference to the University of Florida, contact OIT.

## **17.52. Abbreviations guide for UF labeling standard** **By Sheard Goodwin** Last Revision 5-9-2005

There are a number of abbreviations used in the UF naming and administration standard. Following is a list of the more common ones for your use.

### Common Abbreviations

WAO	work area outlet
RKO	rack outlet
TBB	telecommunications bonding backbone
TMGB	telecommunications main grounding bar
TGB	telecommunications grounding bar
TR	telecommunication room

### Coaxial Elements

XPL	coaxial panel
XDR	coaxial horizontal drop cable

### Copper elements

CPL	copper panel
CUT	unshielded twisted copper cable
CST	shielded twisted copper cable

### Electronic Elements

EMC	media converter
EPN	power injector

### Fiber elements

FMM	multimode fiber cable
FSM	singlemode fiber cable
FCM	composite fiber cable
FPL	fiber panel

### Pathway Elements

PRK	rack
PCB	communication cabinet
PCO	conduit
PTY	splice tray

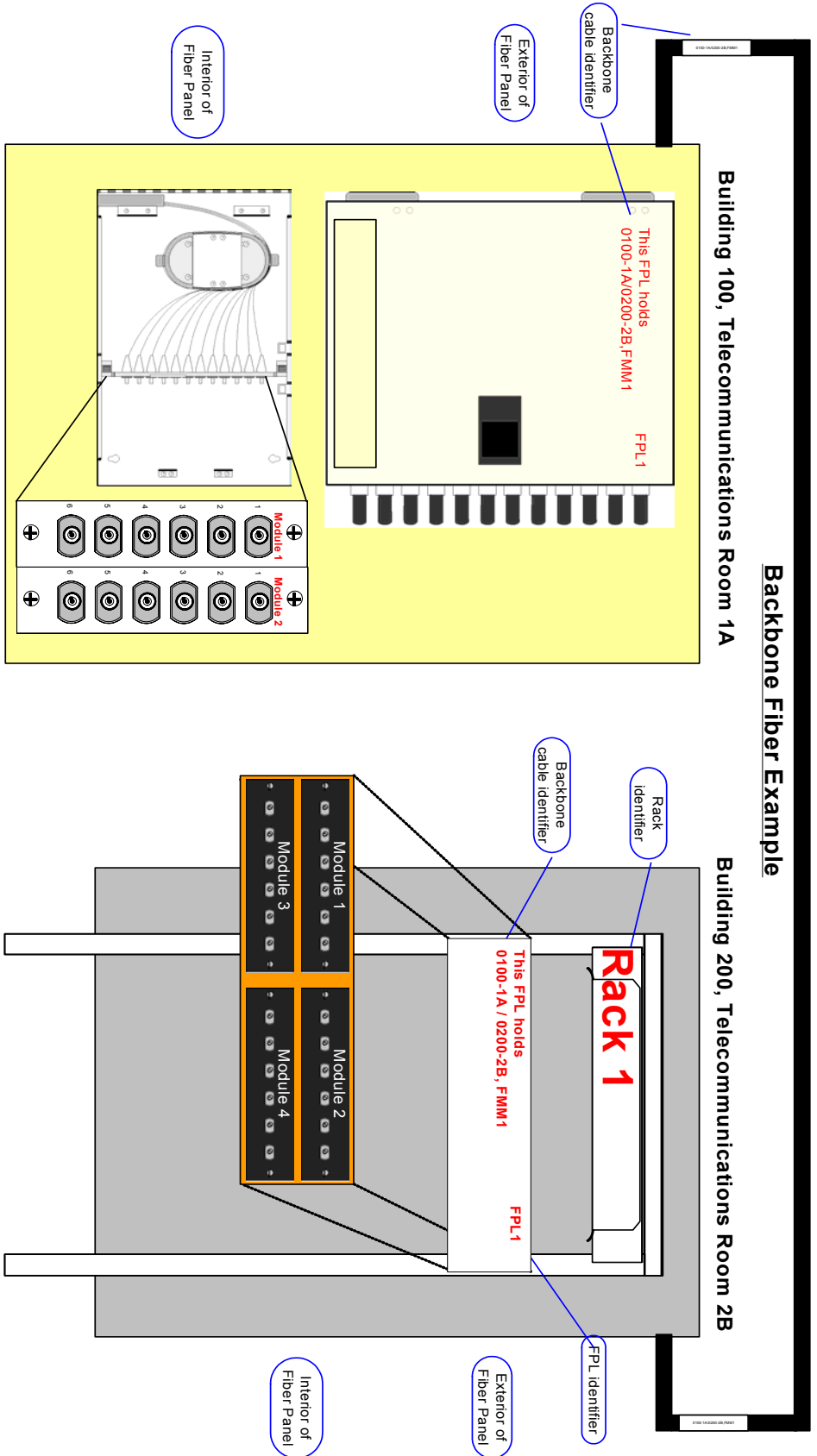

**Backbone UTP example**

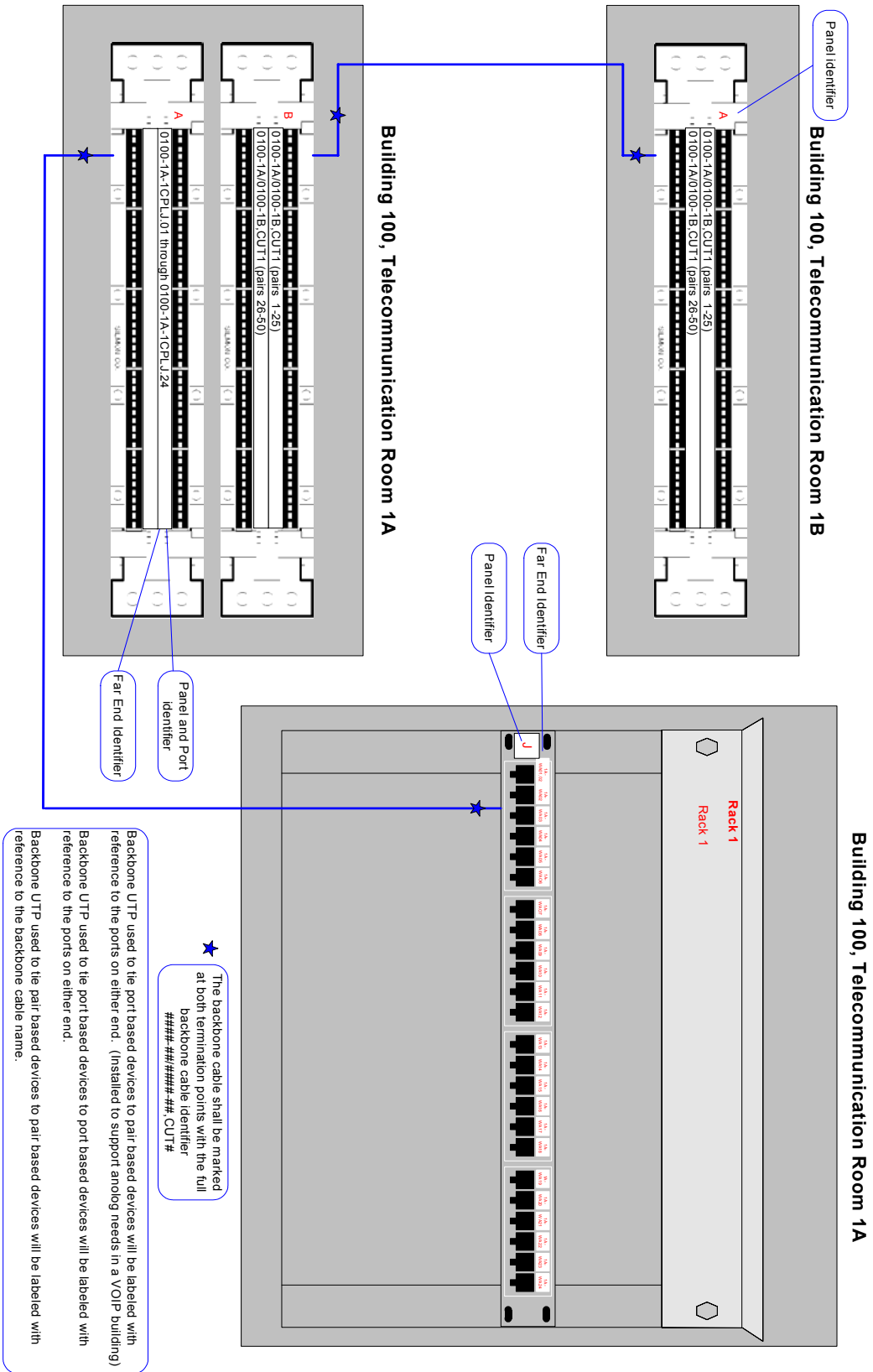

★ The backbone cable shall be marked at both termination points with the full backbone cable identifier  
 #####-###-###.CUT#

Backbone UTP used to the port based devices to pair based devices will be labeled with reference to the ports on either end. (installed to support analog needs in a VOIP building)  
 Backbone UTP used to the port based devices to port based devices will be labeled with reference to the ports on either end.  
 Backbone UTP used to the pair based devices to pair based devices will be labeled with reference to the backbone cable name.

### Horizontal Cable Example

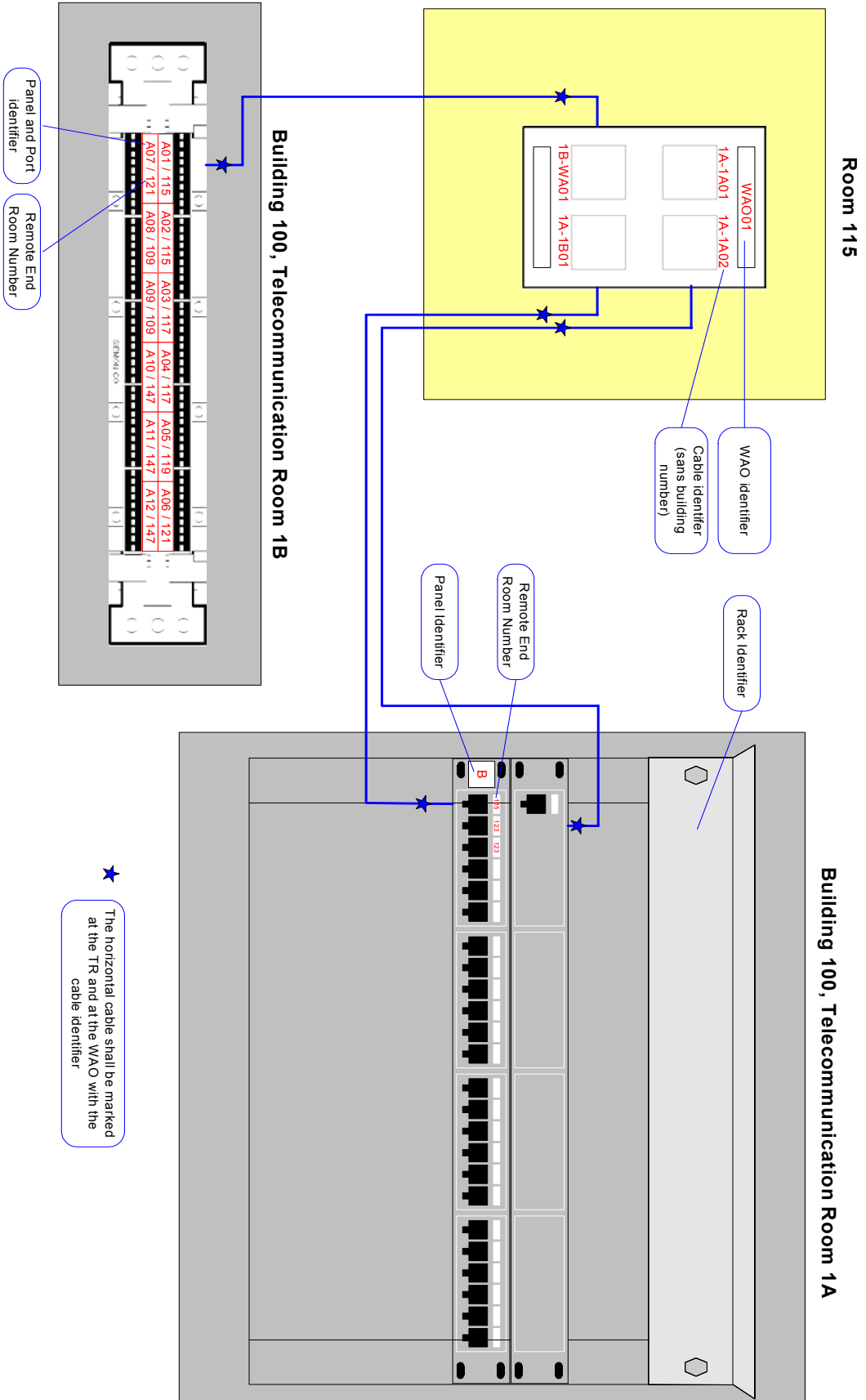

### Horizontal Record Example

Name	Cable Type	TR Termination Point	TR Termination Type	Remote Termination Point	Remote Termination Type	Comments
0127-1A-WA01	Category 5e UTP	0127-1A-WCPLA:01	110 rear punch	0127-0115-WAO01	Panduit CJ688BL	
0127-1A-WA02	Category 5e UTP	0127-1A-WCPLA:01	110 rear punch	0127-0115-WAO01	Panduit CJ688BL	
0127-1A-WA03	Category 5e UTP	0127-1A-WCPLA:01	110 rear punch	0127-0117-WAO01	Panduit CJ688BL	
0127-1A-WA04	Category 5e UTP	0127-1A-WCPLA:01	110 rear punch	0127-0117-WAO01	Panduit CJ688BL	
0127-1A-WA05	Category 5e UTP	0127-1A-WCPLA:01	110 rear punch	0127-0119-WAO01	Panduit CJ688BL	Cable unterminated at WAO

Full name of cable

Full name of Copper Panel Port

TR termination method, if modular plugs are used enter the part number

Full name of Work Area Outlet

Make and Model of WAO jacks

Comments: including lack of termination, nonstandard WAO location, and so on



### Conduit Example

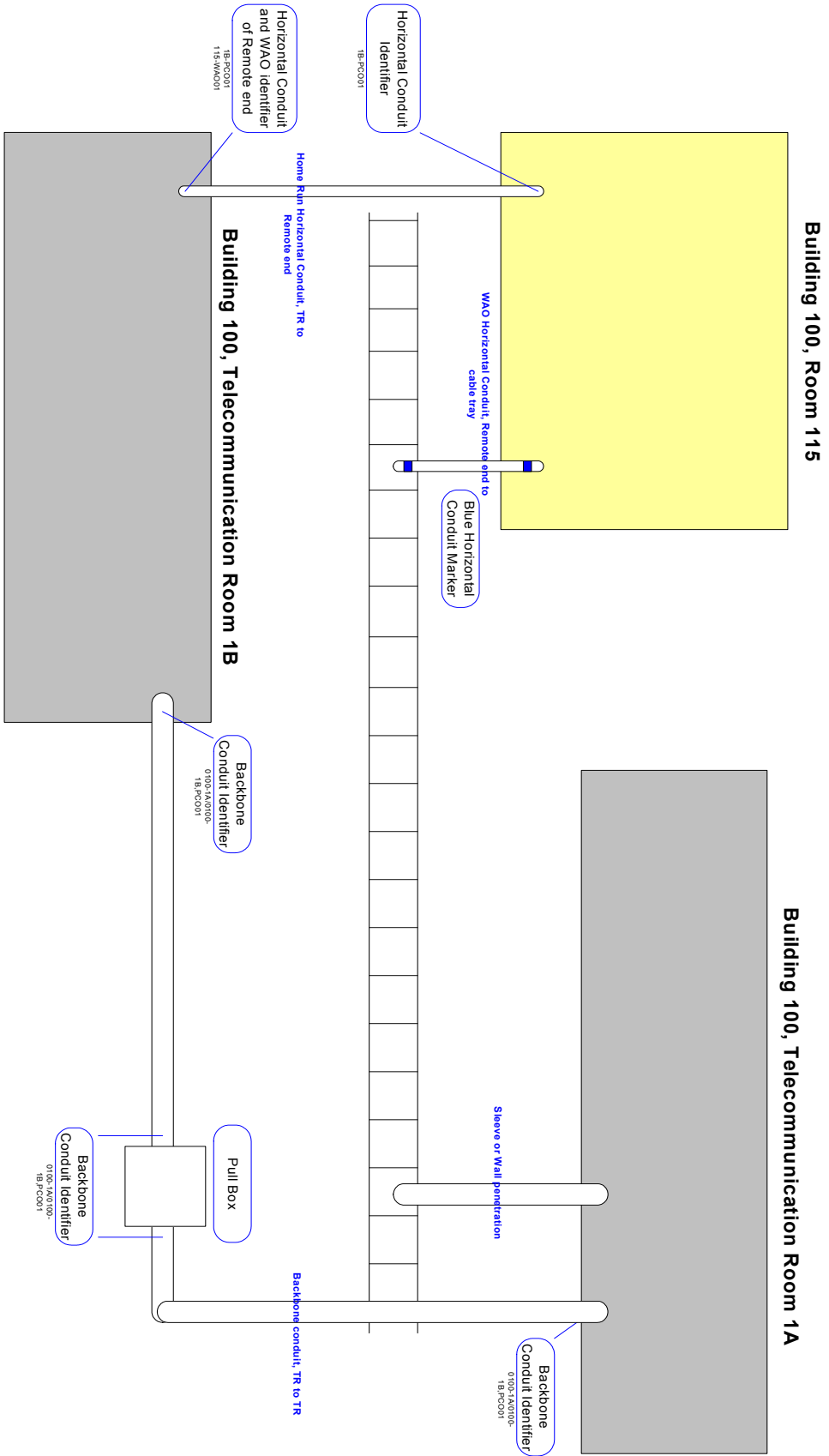

## 18. Appendix #2 -Grounding and Bonding

Appendix 2 - Typical Grounding Busbars

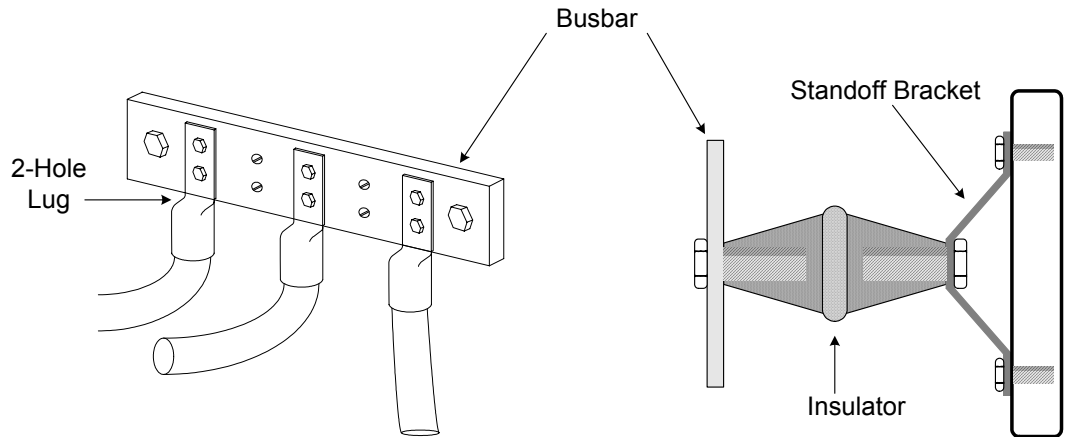

A Telecommunications Bonding Backbone (TBB) conductor is connected from the TMGB to the Telecommunications Grounding Busbar (TGB) in Telecommunications Closets within the building. The minimum dimensions of the TGB are 6 mm (0.25 in) thick, 50 mm (2 in) wide, and variable in length.

A TBB is a conductor that interconnects all the TGBs with the TMGB. The TBB is designed to interconnect busbars and is not intended to have equipment bonding conductors spliced on to it. The minimum TBB size shall be a 6 AWG and could be as large as a 3/0 AWG.

The busbar designated for protectors, the Telecommunications Main Grounding Busbar (TMGB), must safely carry lightning and power fault currents. The TMGB is directly bonded to the electrical service ground. It should be positioned adjacent to the protectors and directly between the protectors and the approved building ground for protector operation. The minimum dimensions of the TMGB are 6 mm (0.25 in.) thick, 100 mm (4 in.) wide, and variable in length.

Typical Telecommunications Grounding System

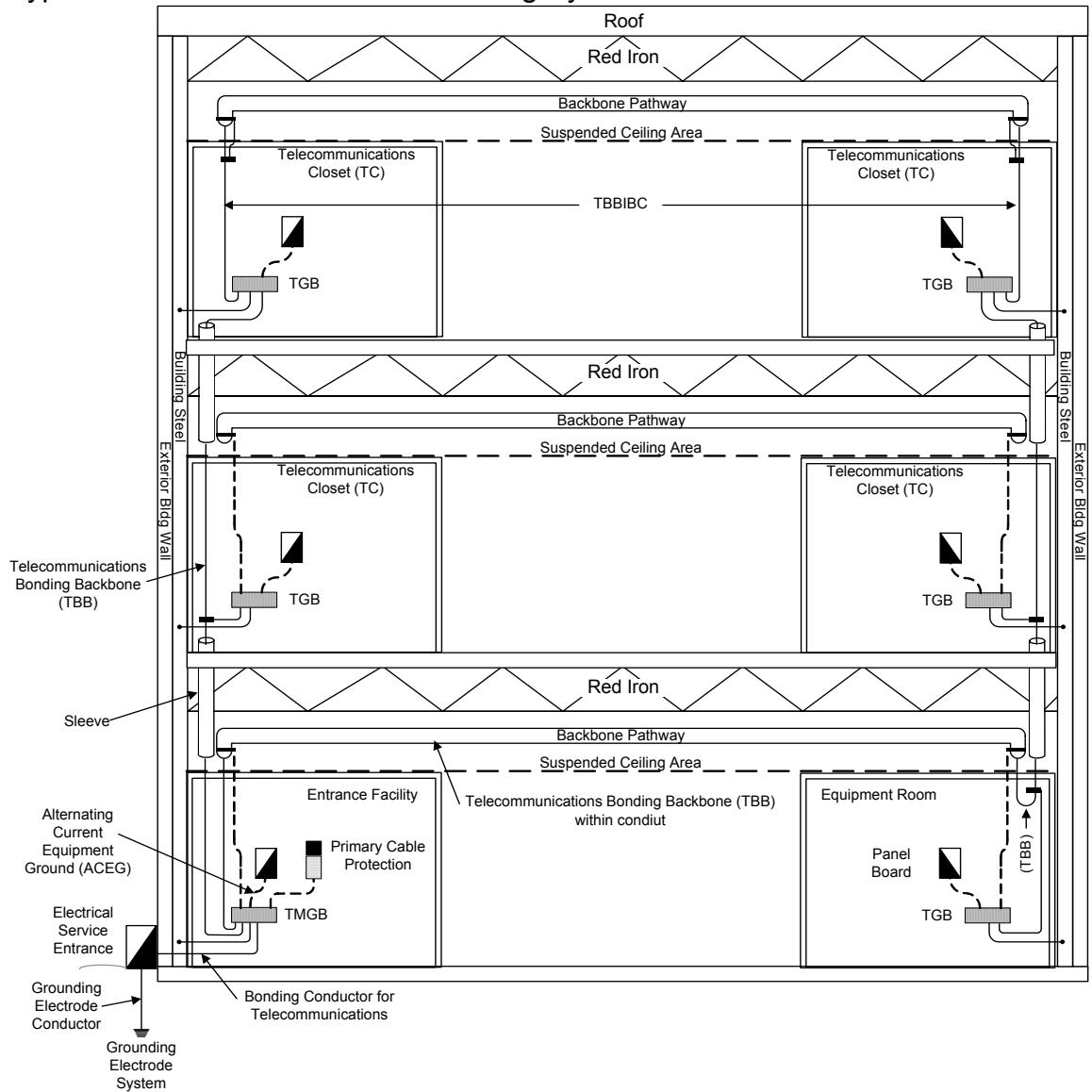

**Glossary**

- TBB** - Telecommunications bonding backbone
- TMGB** - Telecommunications main grounding busbar
- TGB** - Telecommunications grounding busbar
- TBBIBC** - Telecommunications bonding backbone interconnecting bonding conductor

**19. Appendix #3-Telecommunication Room Design Example**  
**Shallow Telecommunications Room Layout Example**

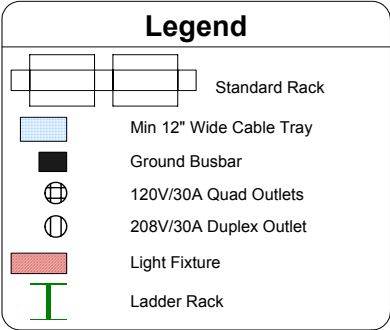
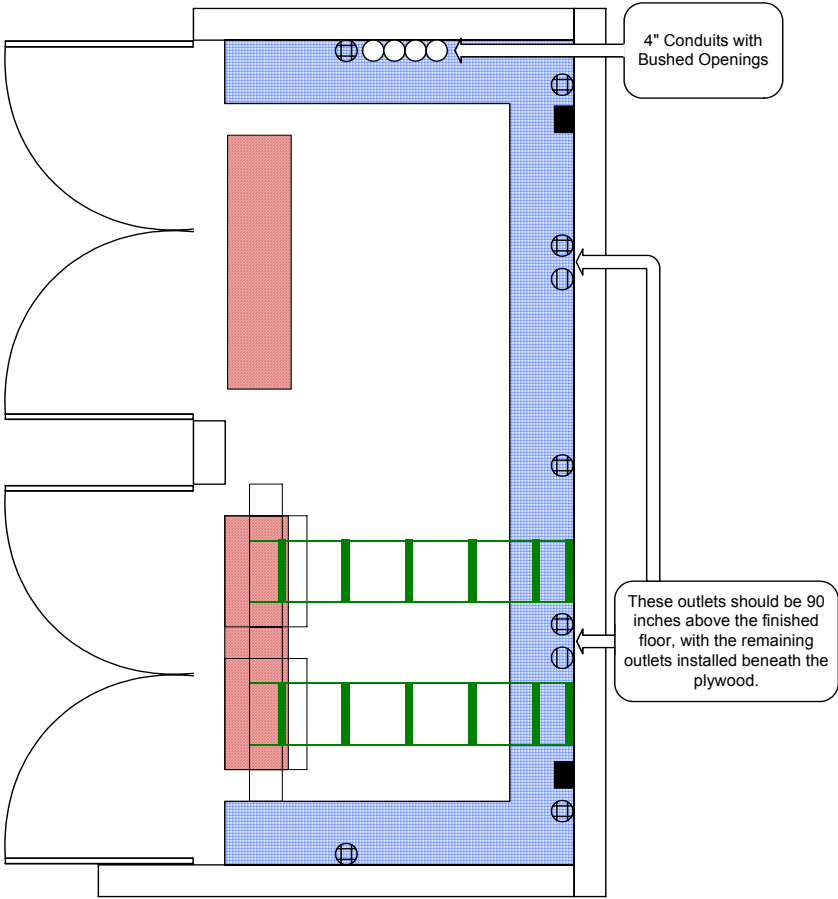

### Walk-in Telecommunications Room Layout Example

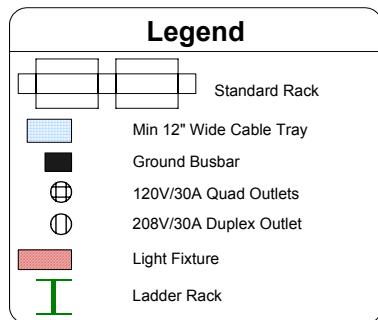
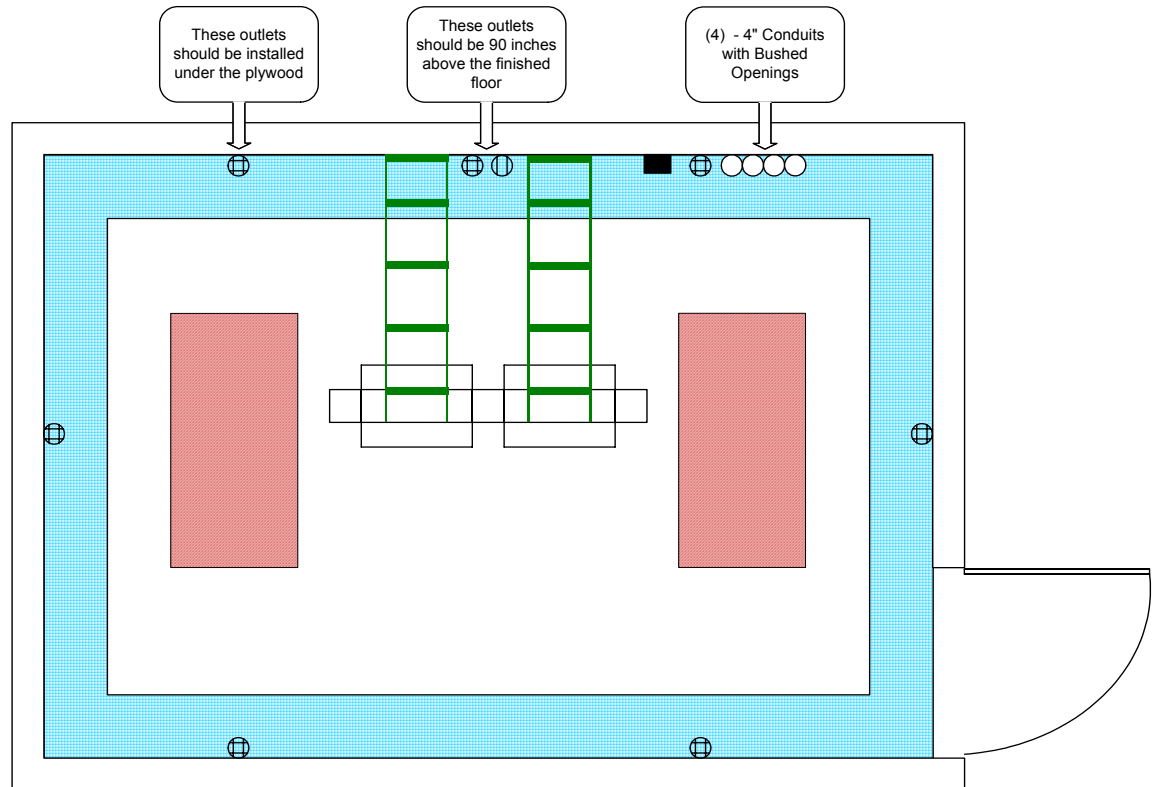

## Side View of Typical Telecommunications Room

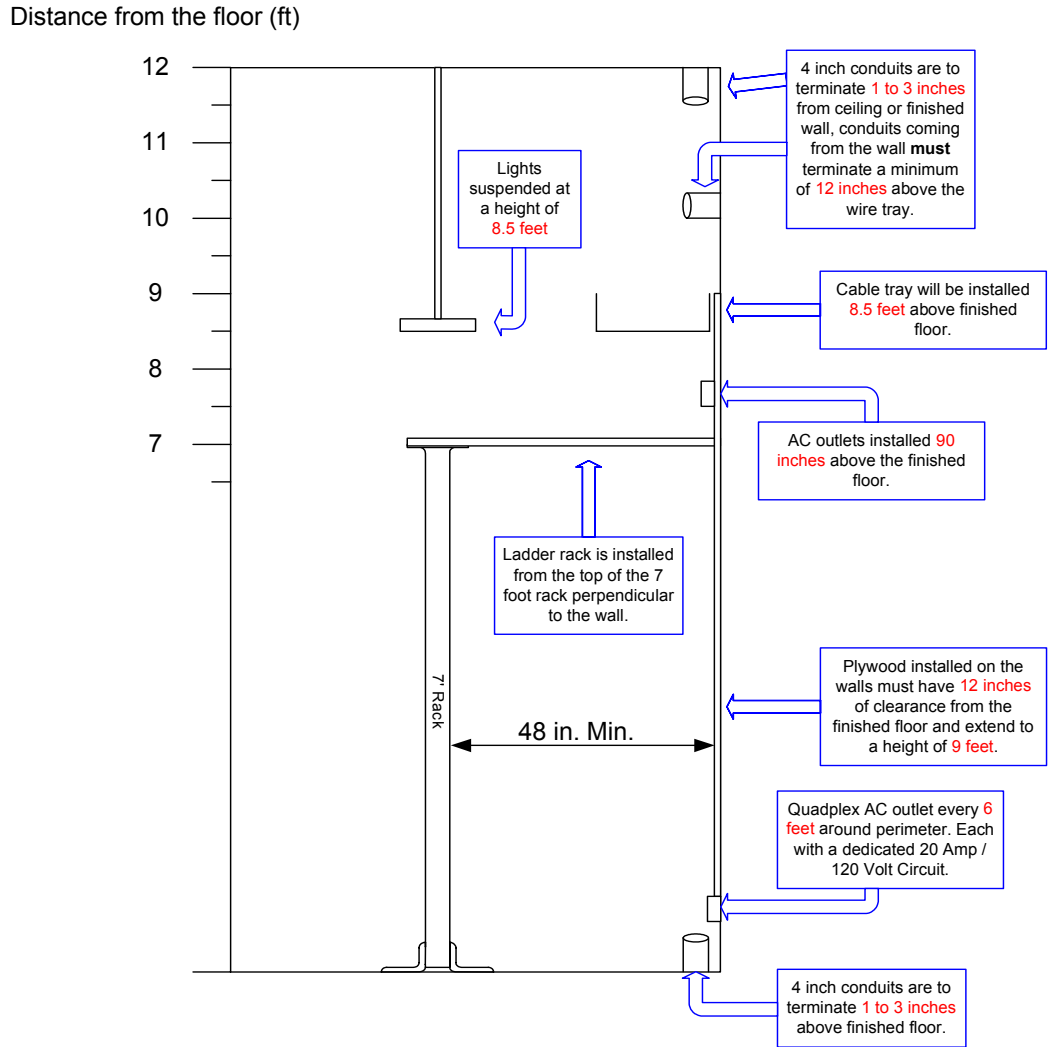

# Typical Rack Layout

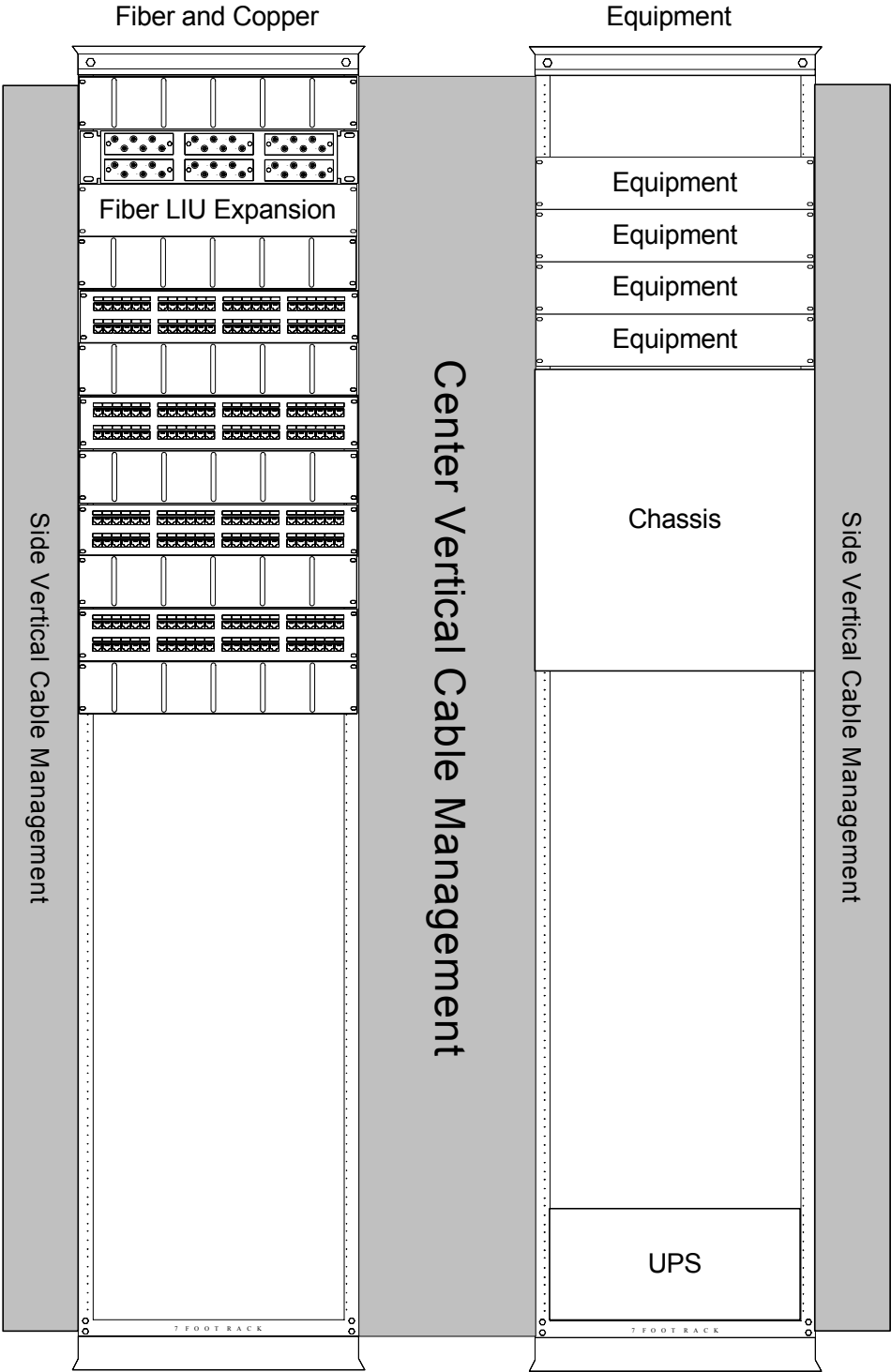

**20. Appendix #4 - Standards Variance Form**

**Telecommunications Standards Variance Request Form**

To request an exception to the University of Florida Telecommunications Standards, complete this form and turn it over to the Facilities Planning & Construction Project Coordinator for the project involved. The OIT Infrastructure Design group will review your request within one week of receipt of your request, approve or deny and contact the Project Coordinator. Deviation from the University of Florida's Telecommunication Standards will not be allowed without the OIT Infrastructure Design group's approval.

Project Coordinator \_\_\_\_\_  
Project involved \_\_\_\_\_  
Date Variance Requested \_\_\_\_\_  
Requesting Agency \_\_\_\_\_

Variance Requested:

\_\_\_\_\_  
\_\_\_\_\_  
\_\_\_\_\_  
\_\_\_\_\_  
\_\_\_\_\_

Reason for Variance Request:

\_\_\_\_\_  
\_\_\_\_\_  
\_\_\_\_\_  
\_\_\_\_\_  
\_\_\_\_\_

OIT Infrastructure Design Group's Approval:

\_\_\_\_\_  
\_\_\_\_\_  
\_\_\_\_\_

Date Approved: \_\_\_\_\_